

# ***Manual*** ***RT-100*** ***Emergency Receiver***

Microprocessorcontrolled Surveillance Receiver  
(Man Overboard)

with two frequencies and special additional functions

**RHO**

Elektronik GmbH

**THEIA**

**Edited by:**

RHOTHETA Elektronik GmbH  
Kemmelpark  
Dr.-Ingeborg-Haeckel-Str. 2  
82418 Murnau  
Germany

Tel.: +49 8841 4879 - 0

Fax: +49 8841 4879 - 15

Internet: [www.rhotheta.de](http://www.rhotheta.de)

E-Mail: [email@rhotheta.de](mailto:email@rhotheta.de)

*Copyrights © RHOTHETA Elektronik GmbH*

*All rights reserved*

*Issue: [2010/03/05] [Rev 1.05]*

**HINT**

The manufacturer reserves on making modifications at any time and without previous information of the product described here.

## Index

<b>Common Hints .....</b>	<b>3</b>
<b>Operation .....</b>	<b>4</b>
<b>Connecting additional devices and power .....</b>	<b>7</b>
<b>Technical Data .....</b>	<b>8</b>
<b>Declaration of Conformity .....</b>	<b>9</b>

## 1 Common Hints

Thank you for buying the RHOTHETA RT-100 Emergency Receiver. The RT-100 Emergency Receiver is a professional Man-over-board surveillance system for the international ELT emergency frequency. In combination with man-carried emergency transmitters as the PLB, high security concerning an unnoticed man-over-board scenario will be obtained.

At this place we would like to ask you to read the User Manual attentively in order to avoid possible problems caused by incorrect handling.

## 2 Operation

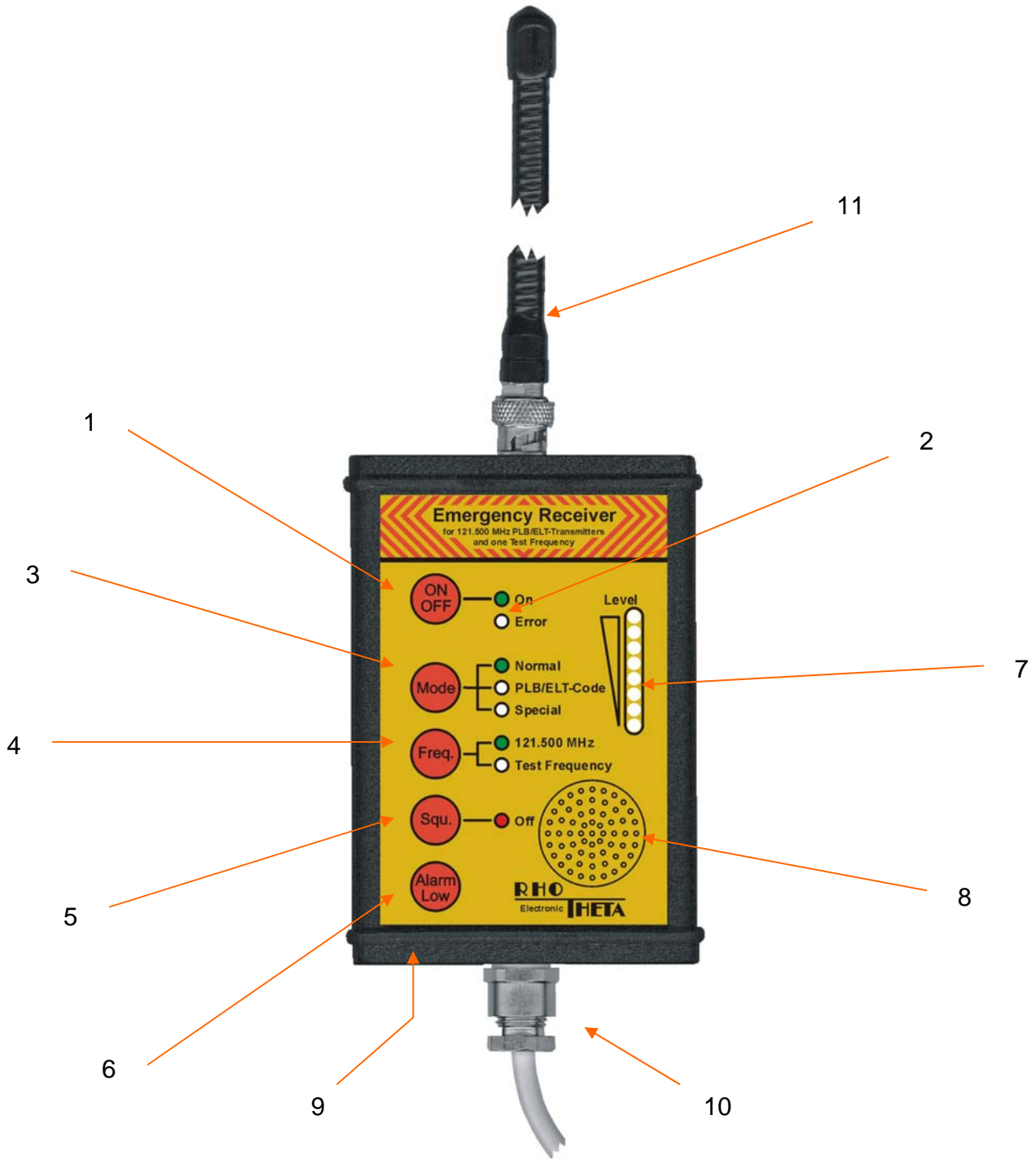

Front view RT-100 Emergency Receiver

- (1) **ON/OFF**-switch of the RT-100 Emergency Receiver. After a short switch-on system test the device is ready to operate. The green LED will flash when switched on.
- (2) When operating a continuous self-diagnosis is executed. In case of detecting an internal fault the red **ERROR-LED** will flash. The RT-100 Emergency Receiver is not working properly anymore.
- (3) The **Mode**-button is used for selecting two different modes of operation. The selected mode will be stored lasting until a new change.
  - **Normal**  
When switched to this mode the RT-100 Emergency Receiver works as a normal receiver. Each received signal on the active frequency will trigger alert. In case of an alarm always an acoustic check should be made, if it is either the typical PLB/ELT howling sound or a false alarm caused by rare, but occurring, short transmissions of pilots or strong disturbing signals.
  - **PLB/ELT-Code.**  
In this mode alert will be triggered only if a PLB/ELT-code signal with typical downswamp is received (criteria of recognition are listed in chapter Technical Data). For triggering alert a certain receiving field strength is required for analysing and recognising the modulation. At the beginning of an alarm an acoustic beep will be given 25 times as additional signal. (The display LED "Special" has no function)
- (4) The **Freq.**-button is used to adjust the active receiving frequency.
  - **121.500 MHz**  
This is the international emergency frequency. All PLB/ELT emergency transmitters are working on this frequency. A green LED indicates that this frequency is active.
  - **Test Frequency** (see chapter "Technical Data")  
This second frequency is used only for testing purposes in combination with a transmitter working on the same frequency, in order not to trigger alert at others (e.g. SAR etc.). A red flashing LED indicates (also as warning) whether this test frequency is activated.
- (5) The **Squ.**-button switches the squelch-function (ON/OFF). This function is used mainly for checking the receiver. If the green Off-LED is lit, the squelch is switched off and an acoustic noise on the speaker can be heard. This function does not affect the squelch level or triggers alert.

- (6) The **Alarm-Low**-button disables (if alert is triggered) resp. enables internal/external speakers; in addition the switching contact of the alarm-relay is also deactivated. If there is no alarm, this function will be switched on automatically after 60 sec. in order to assure warning after a forgotten switch-off.
- (7) The 16-stepped **level indicator** displays the field strength of the incoming signal. The field strength is also a relative measure for the distance to the transmitter. If there is a level value between two LEDs, the next upper LED will flash.
- (8) Integrated **speaker** indicates alarm and gives an acoustic control of the incoming signal. Additionally each registered touch of the buttons will be acknowledged by a short beep.
- (9) • At this position, after removing the lower cover (for this you will have to open first the two screws), a potentiometer for adjusting the squelch level is situated. The squelch has to be adjusted such insensitive that it is guaranteed that no strong disturbing signals will be received. When adjusting, it is very important to change into the "Normal" mode in order to hear the actual squelch level.
  - Turning the potentiometer clockwise ↻ => squelch less sensitive
  - Turning the potentiometer anticlockwise ↻ => squelch more sensitive
- (10) Connecting **cable** for power supply and other additional devices.
- (11) Receiving **antenna** with BNC-connector

## 3 Connecting additional devices and power at the connecting cable

### 3.1 Power

⊙(+12 V ... 24V DC) = colour **red**,    ⊙(GND) = colour **black**

### 3.2 Additional speaker, audio exit

An additional external speaker may be connected (8 Ω minimum) at the connecting cable:

⊙(Speaker +) = colour **orange**,    ⊙(Speaker - ) = colour **brown**.

### 3.3 Relay contact

The Emergency Receiver contains a relay which is switching a contact between the cables ⊙colour **green** and ⊙colour **yellow**, if alarm is triggered.

#### Optional:      Connection Table for Sub-D-Connector

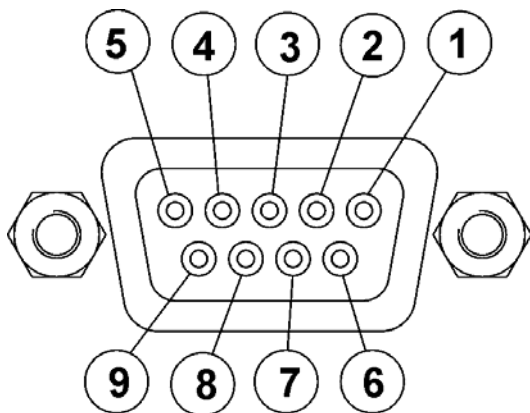

Signal	Pin
GND	5
+12 V ... 24 V	9
Speaker -	1
Speaker +	6
Relay contact	2
Relay contact	7
not used	3, 4, 8

## 4 Technical Data

- Dimensions: width x height x depth:  
85 mm x 115 mm x 35 mm (without antenna)
- Weight: 350 g
- Temperature range: -20 °C ... +60 °C
- Protective system: IP 65 (dustproof and splashproof)
- Sensitivity: < 0.5  $\mu$ V at antenna input
- Receiving frequency: 121.500 MHz (channel 1 / ELT frequency)  
121.650 MHz (channel 2 / test frequency)
- Criteria of ELT recognition: audible AM-modulated howling, downward;  
LF-range within 300 Hz ... 1600 Hz,  
LF-range 700 Hz minimum,  
time of repetition: 250 ms ... 500 ms,  
 $\Delta$ LF/25ms: -10 Hz ... -250 Hz
- Audio exit: max. 8 V<sub>ss</sub> (speaker > 8  $\Omega$ )
- Relay contact (NOC): floating, carrying capacity max. 0.5 A / 10 W
- Current Drain  
Standby: 80 mA  
Alarm + ext. speaker (8  $\Omega$ ): 400 mA
- Operating voltage: +12 V ... 24 V DC ( $\pm$  20%)



Document No. 98-07-27

We hereby declare that the product:

Type of product:  
RT-100 Emergency Receiver  
(CrewGuard)

Product designation:  
SAR-Monitoring-Receiver

is in conformity with the following directives of the Council of the European Union for the approximation of the laws of the Member States:

- Low Voltage Directive (LVD)  
73/23/EEC modified by 93/68/EEC
- Electromagnetic Compatibility Directive (EMC)  
89/336/EEC modified by 91/263/EEC, 92/31/EEC, 93/68/EEC

The conformity is proved by the observance of the following standards:

<b>Provision(s):</b>	<b>Standard(s):</b>
Emitted interference: ETS 300 683: 1997	CENELEC EN 55 022: Conducted emission Electric field strength
Interference resistance: ETS 300 683: 1997	CENELEC EN 61 00-4-2:1995 CENELEC EN 61 00-4-3:1995 CENELEC EN 61 00-4-6:1995 ISO 7637-1 :1990 ISO 7637-2 :1990

RHOTHETA Elektronik GmbH  
Neuegling 7, D-82418 Murnau

Murnau 16.08.2005

**Own notes:**

