

RT-300

NMEA

Serial Communication & Remote Control

Documentation

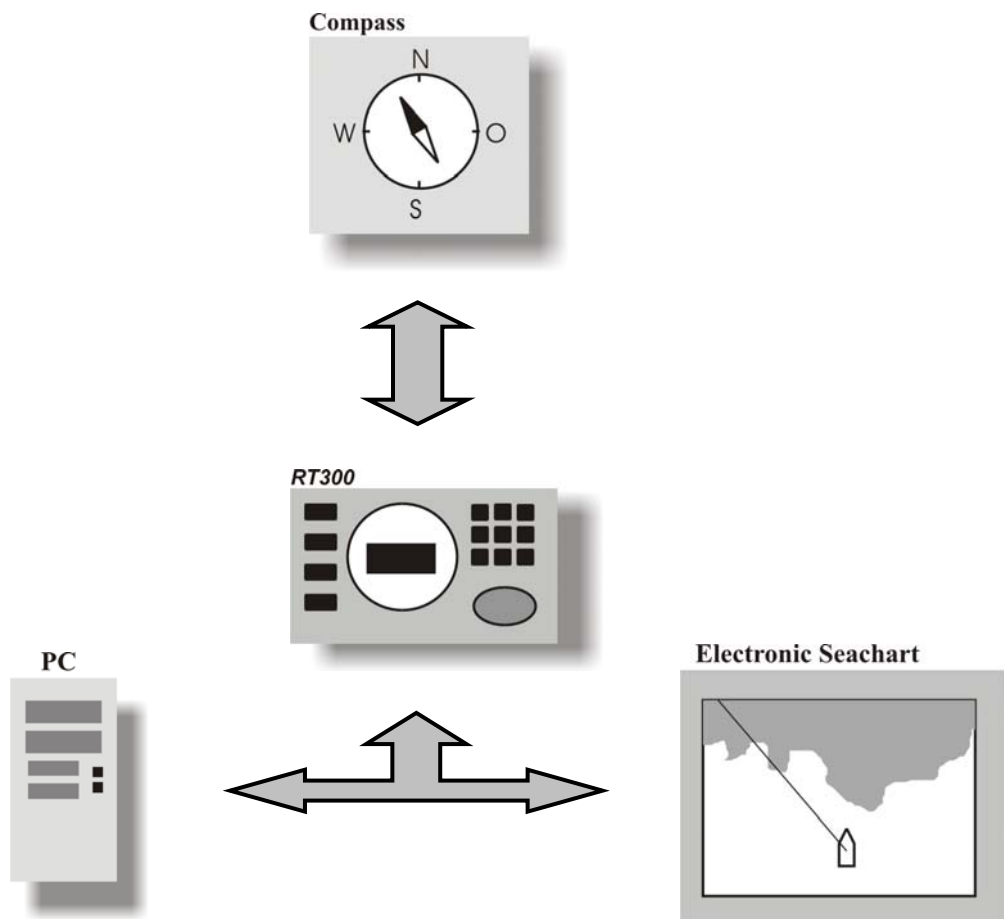

Edited by:

RHOTHETA Elektronik GmbH
Kemmelpark
Dr.-Ingeborg-Haeckel-Str. 2
82418 Murnau
Germany

E-Mail: email@rhotheta.de
Internet: www.rhotheta.de

*Copyright ©2000...2009 by RHOTHETA Elektronik GmbH
All rights reserved*

The company assumes no responsibility for any errors which may appear in this document or in the described device, reserves the right to change specifications detailed herein at any time without notice, and does not make any commitment to update the information contained herein.

1. Change Log

Revision	Date	Changes
1.00	28.01.2003	- first official release
1.01	04.05.2004	- added sentences: STAT,SETSTAT
1.02	11.06.2004	- corrected headline 2.1.3 (HEDT)
1.03	21.07.2004	- added sentences: PHASECAL - removed request sentence descriptions - removed default band field in sentence INFREC - changed flag in INFBAND from "A" to "T" - removed "AF" from special mode types (INFDCU) - added control sentences: RXTYPE,TALKMODE
1.04	05.11.2004	- modified INTCOMP data sentence (for 3 axis compass)
1.05	19.01.2005	- added request sentence EXTIN - added Data Out sentence EXTIN - added sentences OFFSET - added control sentence BEEP - added control sentence LEDON - added control sentence LCDON - added control sentence TESTPORT - added control sentence RELAY - added control sentence EXECBUTTON - added control sentence DEMO - added control sentence AVERAGING - extended parameter for phasecal control sentence
1.10	21.11.2007	-changed DFSTD sentence ("D" for BeaconID) - added BID-Request and INFBID-Response - changed xxHDT compass sentence - added xxHDM compass sentence
1.11	26.11.2007	- changed INFDCU - few minor corrections
1.12	05.12.2007	- added SETHWREV an SETDEVID-sentence
1.13	20.04.2009	- minor change: company address changed

Contents

1. CHANGE LOG	3
GENERAL.....	3
1.1 DATA FORMAT	3
1.2 DATA PROTOCOL	3
1.3 TIMING.....	3
1.4 CONNECTION.....	3
1.4.1 Without sentence request and remote control.....	3
1.4.2 With sentence request and remote control from sea chart	3
1.4.3 With sentence request and remote control from PC	3
1.4.4 Multiple DF connected via RS485 to one PC	3
2. SUPPORTED SENTENCES/COMMANDS	3
2.1 HEADING INPUT SENTENCES	3
2.1.1 HCHDG - Heading, deviation and variation.....	3
2.1.2 xxHDT - True heading	3
2.1.3 xxHDM - Magnetic heading.....	3
2.2 DATA REQUEST SENTENCES.....	3
2.2.1 GEN General info request	3
2.2.2 PART Part info request	3
2.2.3 REC Receiver info request.....	3
2.2.4 DCU Display control unit info request	3
2.2.5 BAND Receiver band info request.....	3
2.2.6 INTCOMP Internal compass data request	3
2.2.7 DFSTD DF standard data request.....	3
2.2.8 IVOLT Voltage data request	3
2.2.9 AF Audio frequency data request	3
2.2.10 STAT Statistics data request	3
2.2.11 DIMC Dimming/contrast settings request	3
2.2.12 VOL Volume settings request	3
2.2.13 PHASECAL Phase calibration setting request.....	3
2.2.14 EXTIN External input Status request.....	3
2.2.15 OFFSET Bearing offset request.....	3
2.2.16 BID Beacon-Information request	3
2.3 DATA OUT SENTENCES	3
2.3.1 INFGEN General info sentence	3
2.3.2 INFPART Part info sentence	3
2.3.3 INFREC Receiver info sentence.....	3
2.3.4 INFDCU DCU Info Sentence.....	3
2.3.5 INFBAND Band info sentence	3
2.3.6 INTCOMP Internal compass data sentence	3
2.3.7 DFSTD Standard DF sentence	3
2.3.8 IVOLT Internal voltages data sentence	3
2.3.9 AF Audio frequency data sentence	3
2.3.10 DIMC Dimming/contrast data sentence	3
2.3.11 VOL Volume data sentence	3
2.3.12 STAT Statistic data sentence.....	3

2.3.13 PHASECAL	Phase calibration data Sentence	3
2.3.14 EXTIN	External Input status Sentence.....	3
2.3.15 OFFSET	Bearing offset data Sentence	3
2.3.16 INFBID	Beacon Information sentence.....	3
2.3.17 CMDOK	Command OK.....	3
2.3.18 ERRCMD	Command unknown error.....	3
2.3.19 ERRFIELD	Field unknown error.....	3
2.3.20 ERRRANGE	Field value out of range error	3
2.4	REMOTE CONTROL SENTENCES.....	3
2.4.1 EEOP	Load/Save values from/to eeprom.....	3
2.4.2 FREQU	Set receiving frequency & band.....	3
2.4.3 SQU	Set squelch threshold	3
2.4.4 MODE	Set special operating modes	3
2.4.5 DIMC	Set dimming/contrast	3
2.4.6 VOL	Set volumes.....	3
2.4.7 BAUD	Set serial baud rate	3
2.4.8 RXTYPE	Set serial RX Type.....	3
2.4.9 TALKMODE	Set serial talking mode.....	3
2.4.10 ICOMPAL	Internal compass calibration	3
2.4.11 SETSERIAL	Set serial number.....	3
2.4.12 SETHWREV	Set hardware revision	3
2.4.13 SETDEVID	Set device ident.....	3
2.4.14 ALARM	Send acoustic alarm.....	3
2.4.15 REBOOT	Reboot system	3
2.4.16 FACTRESET	Restore all factory (default) settings	3
2.4.17 SWOFF	Switch off system.....	3
2.4.18 PHASECAL	Phase calibration	3
2.4.19 SETSTAT	Set statistic values	3
2.4.20 OFFSET	Set bearing offset value	3
2.4.21 BEEP	Beep generation	3
2.4.22 LEDON	All LED's on command.....	3
2.4.23 LCDON	All LCD digits black	3
2.4.24 TESTPORT	Route signal to output of testport.....	3
2.4.25 RELAY	Pull the internal relay	3
2.4.26 EXECBUTTON	Execute button test page.....	3
2.4.27 DEMO	Control demo mode	3
2.4.28 AVERAGING	Set averaging level.....	3

General

1.1 Data Format

This direction finder supports NMEA 0183 as default communication method. If NMEA was selected as serial RX hardware in setup menu, the DF is compatible to NMEA 0183 Version 3.01 Standard (including galvanic isolation at the listener side).

Data RX/TX parameters:

Supported baud rates:	1.2k, 2.4k, 4.8k(NMEA 0183 Std.), 9.6k, 14.4k, 19.2k, 28.8k, 38.4k(NMEA 0183 HS Std.), 57k6, 76k8, 115.2k
Data bits:	8 (d7=0)
Parity:	None
Stop bits:	One

Baud rate is selectable in setup menu. We recommend to use 4.8k or 38.4k to be compatible with NMEA0183 or either NMEA0183HS.

1.2 Data Protocol

For receiving external headings (for use as internal magn. or true reference) a set of NMEA 0183 approved sentences are supported (chapter: 2.1). Further sentences are available upon request via software update of the DF-DCU. For remote control and data out of the unit, a set of NMEA0183 proprietary sentences was created (chapter 2.2-2.4).

1.3 Timing

No special timing requirements are necessary. The DF is capable to work with up to 10 remote commands (requests) per second. Further commands (or requests) will be ignored. We recommend a time out for the answer to a request or a control sentence of 250ms.

1.4 Connection

1.4.1 Without sentence request and remote control

This example shows a standard RT-300 peripheral configuration.
This configuration is suitable for most applications.

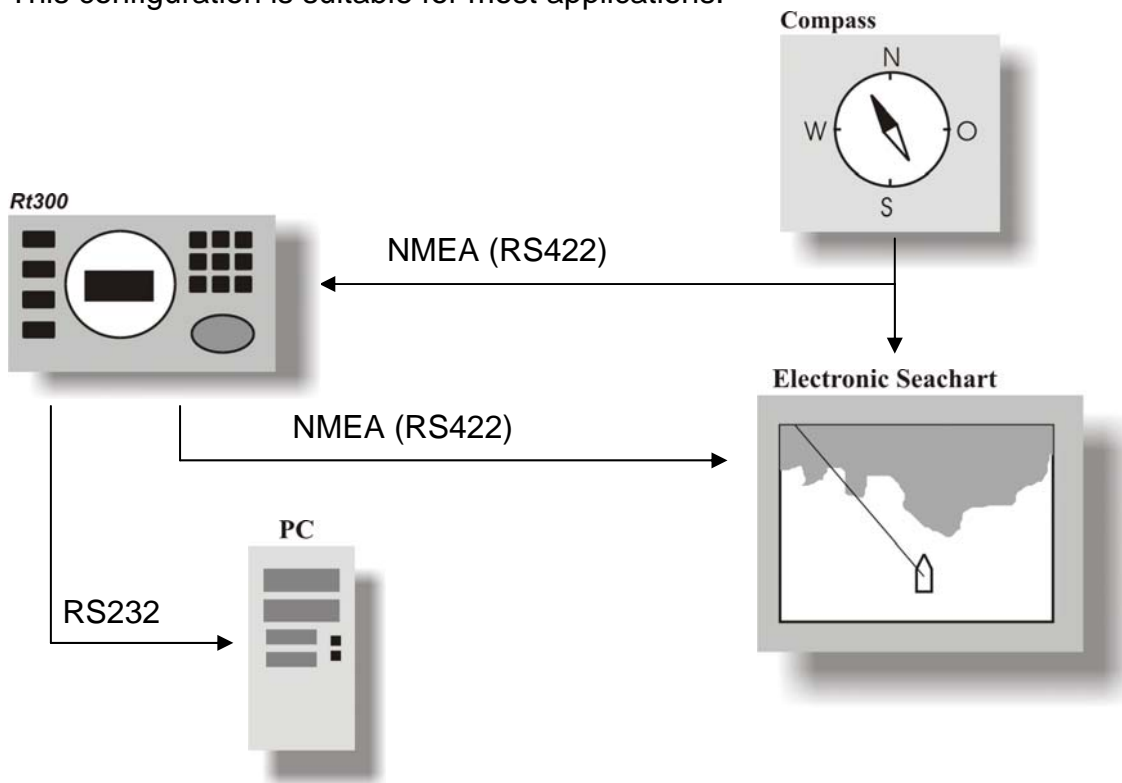

DF configuration:

Serial protocol: NMEA
Serial input: NMEA
Talk mode: Auto
Talk time: 250ms

At the DF the serial input NMEA(RS422) was selected. The data output of the electronic compass or gyro is connected to the galvanic isolated RS422 input of the DF. The electronic sea chart is connected to the RS422 output of the DF. The optional PC is connected to the RS232 output.

With this configuration, there is no remote control or sentence request possible. Therefore it is required to select auto talk mode in serial setup. Then the DFSTD sentence will be transmitted periodically. This sentence contains all important receiver and bearing information's. The repeat time is selectable with the auto talk time parameter in the DF serial setup. We recommend an auto talk time of 250 ms.

1.4.2 With sentence request and remote control from sea chart

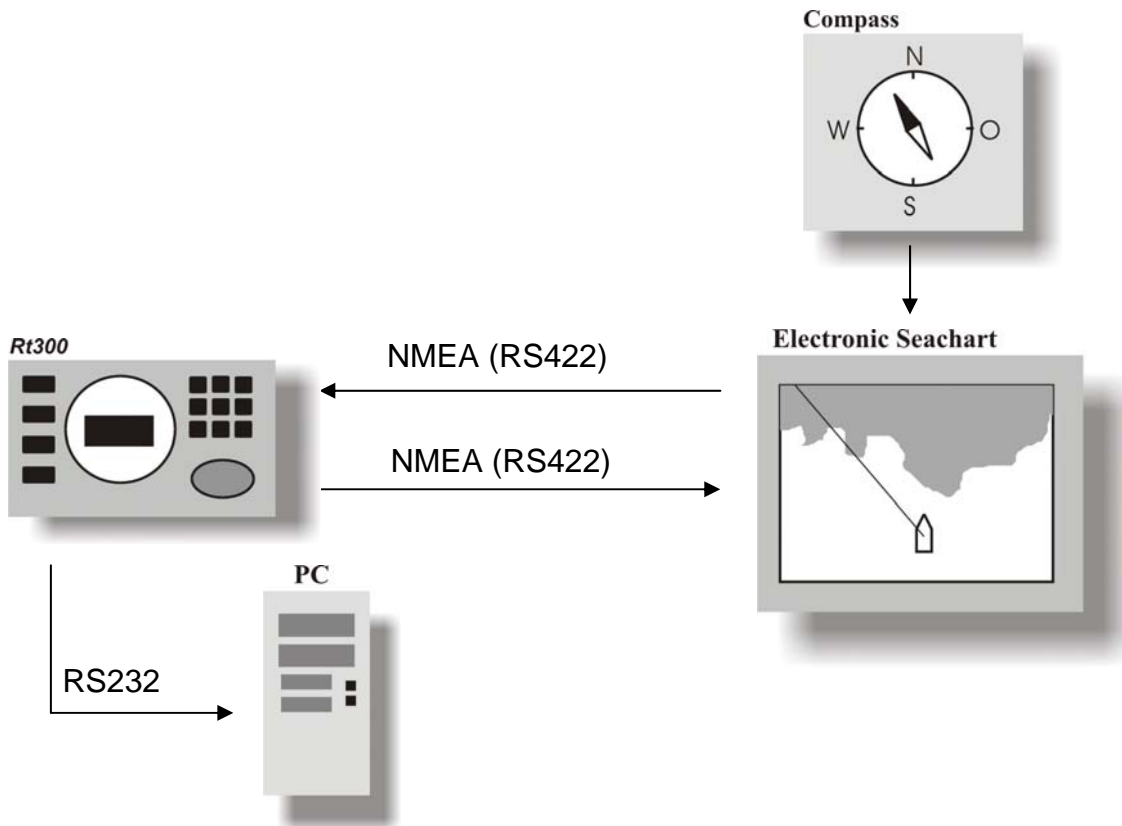

DF configuration:

Serial protocol: NMEA
 Serial input: NMEA
 Talk mode: Request
 Talk time: - (no influence)

At the DF the serial input NMEA(RS422) was selected. The data output of the sea chart is connected to the galvanic isolated RS422 input of the DF. The electronic sea chart input is connected to the RS422 output of the DF. The optional PC is connected to the RS232 output.

In this configuration the sea chart can request information from the DF and is able to remote control the DF. The sea chart provides the DF with heading information too.

1.4.3 With sentence request and remote control from PC

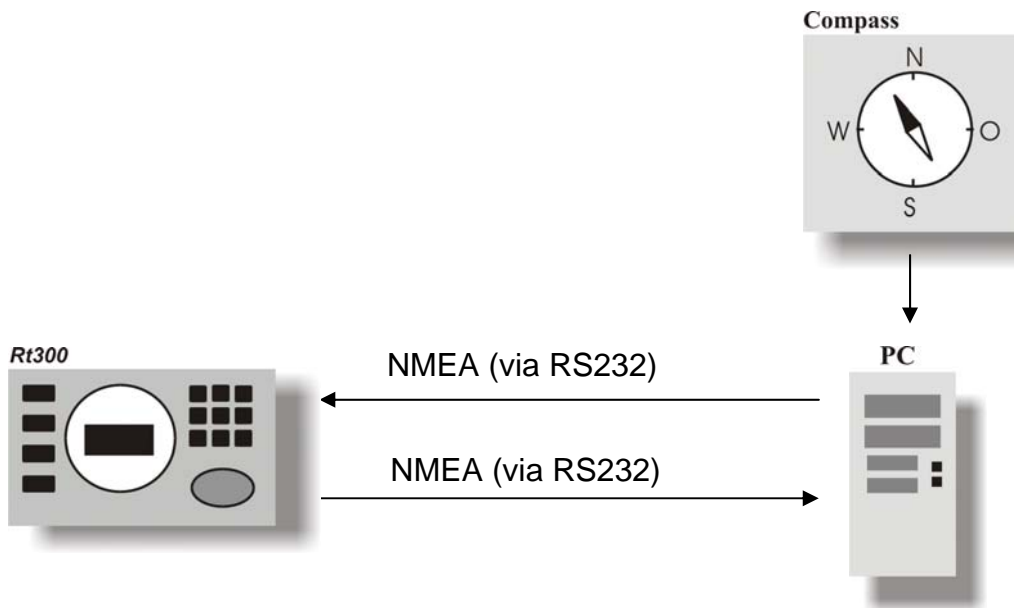

DF configuration:

Serial protocol: NMEA
Serial input: RS232
Talk mode: Request
Talk time: - (no influence)

At the DF the Serial Input NMEA(RS422) was selected. The data output of the PC is connected to the RS232 input of the DF. The PC input is connected to the RS232 output of the DF.

In this configuration the PC can request information from the DF and is able to remote control the DF. The PC provides the DF with heading information too.

1.4.4 Multiple DF connected via RS485 to one PC

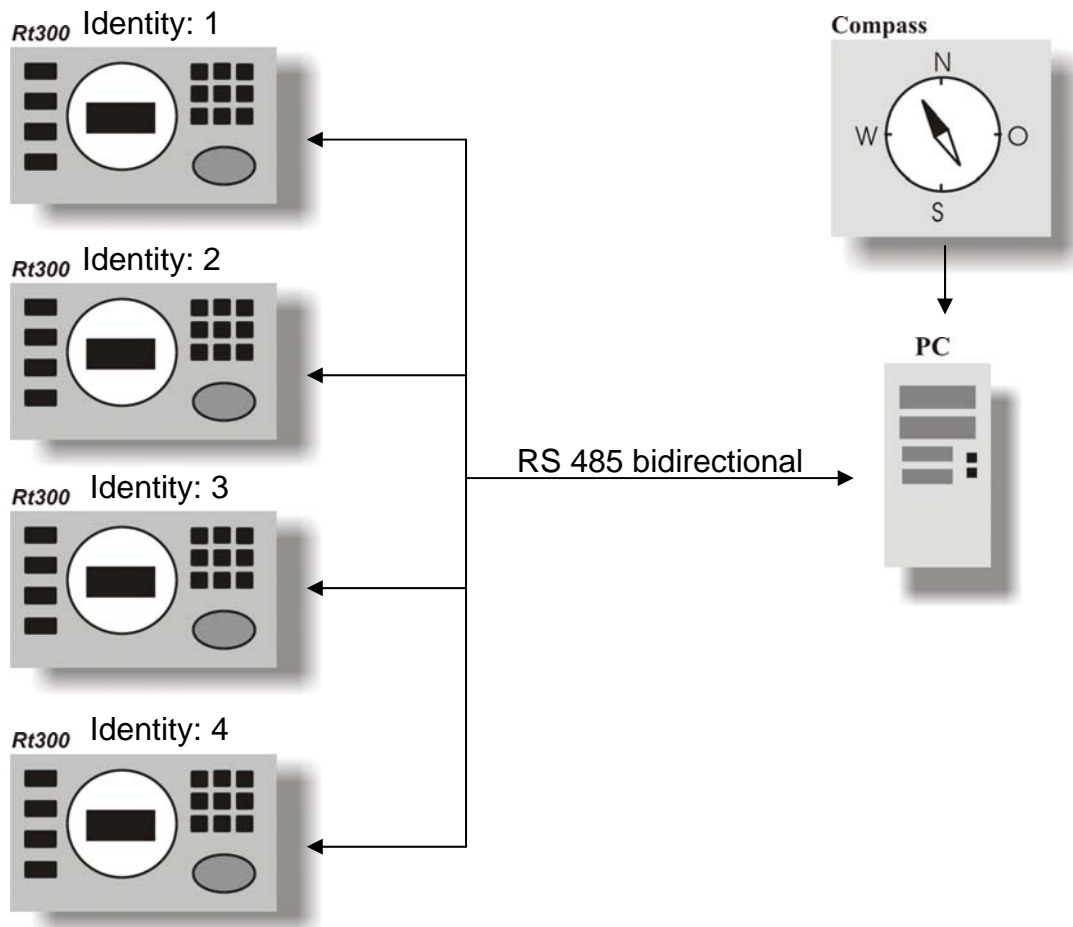

DF configuration:

Serial protocol: NMEA
 Serial input: RS485
 Talk mode: Request
 Talk time: - (no influence)
 Identity: 1...4

All devices are connected together over the 2-wire bidirectional RS485 Bus.

In this configuration the PC can request information from every DF and is able to remote control each DF. The PC provides the DF's with heading information too. The separation of the DF's is possible due to different serial identities.

2. Supported sentences/commands

2.1 Heading input sentences

These approved NMEA0183 sentences are used to tell the DF the actual heading from an external compass, gyro or GPS. The external heading can be used as magnetically or true heading reference (selectable via setup menu). For detailed structure of approved sentences please refer to the original NMEA0183 documentation.

2.1.1 HCHDG - Heading, deviation and variation

\$HCHDG, x.x, x.x, a, x.x, a*hh<CR><LF>

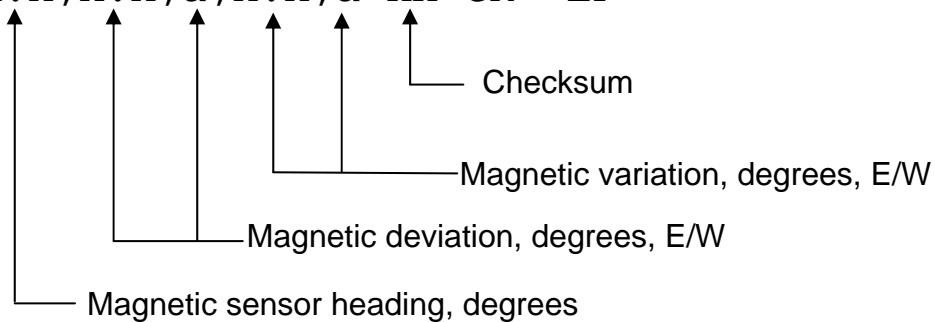

2.1.2 xxHDT - True heading

Remark: xx can be HC, HE, or any other prefix!

\$XXHDT, x.x, T*hh<CR><LF>

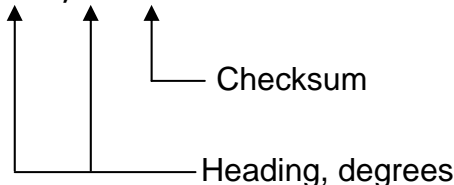

2.1.3 xxHDM - Magnetic heading

Remark: xx can be HC, HE, or any other prefix!

\$XXHDM, x.x, M*hh<CR><LF>

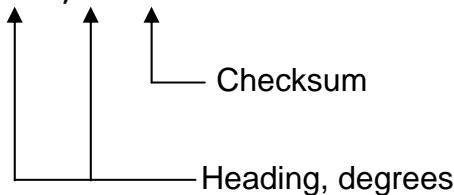

2.2 Data request sentences

Data out of the DF is requested by a proprietary NMEA 0183 sentence. For every data type was an own request sentence created. The request sentence body consists always of the following elements:

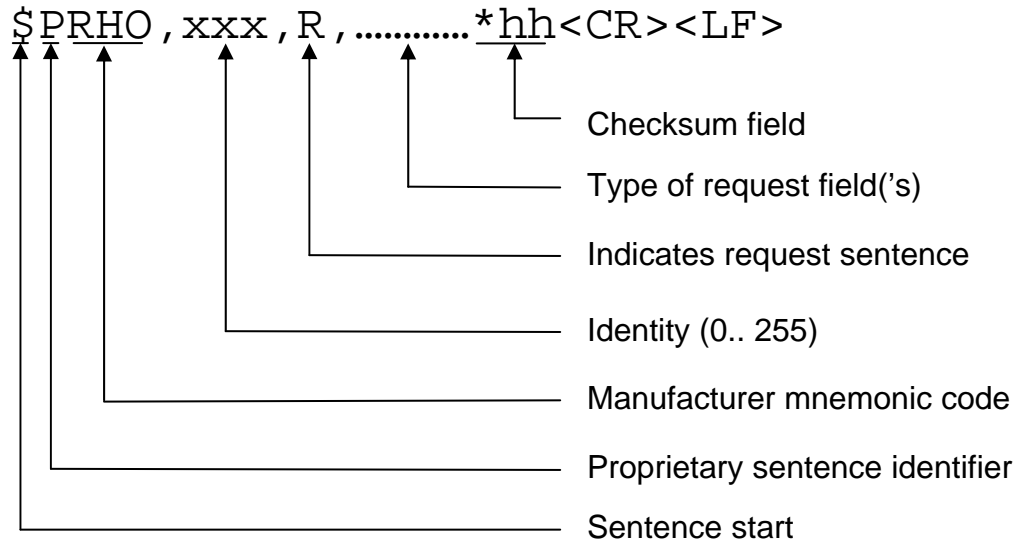

xxx is an identity field of numeric characters. The value must be in the range of 0 to 255. The usable format is equal to NMEA0183 definition of numeric fields (004=04=4). The DF only reacts to the request if the identity is 255 or its equal to the one selected in setup. So the identity allows it to access different DF's connected to one TX.

2.2.1 GEN General info request

\$PRHO , xxx , R , GEN*hh<CR><LF>

This sentence requests a general info.

General Info contains:

- Type of Device
- Device Family
- Name of Device Parts

The answer to this request sentence is described in Chapter 2.3.1

2.2.2 PART Part info request

\$PRHO , xxx , R , PART , c--c*hh<CR><LF>

↑
Name of part

This sentence requests a general part info.

Allowed part names are:

- REC (Receiver unit)
- DCU (Display control unit)

Device info contains:

- Variant
- Serial. no.
- Hardware revision
- Software revision

The answer to this request sentence is described in chapter 2.3.2

2.2.3 REC Receiver info request

\$PRHO , xxx , R , REC*hh<CR><LF>

This sentence requests a general receiver info.

Receiver Info contains:

- Number of receiving bands included
- Possible demodulation types
- Receiver channel spacing
- Onboard compass available

The answer to this request sentence is described in chapter 2.3.3

2.2.4 DCU Display control unit info request

\$PRHO , xxx , R , DCU*hh<CR><LF>

This sentence requests a general receiver info.

Receiver info contains:

- "Scan Mode" available
- "Only ELT" available

The answer to this request sentence is described in chapter 2.3.4

2.2.5 BAND Receiver band info request

\$PRHO , xxx , R , BAND , c--c*hh<CR><LF>

↑
Band number

This sentence requests a general receiving band info.

For the standard RT-300 following band numbers are available:

- 0
- 1

Band info contains:

- Default demodulation in this band
- Band start frequency
- Band stop frequency
- Band default frequency
- Flag: Band includes an emergency frequency

The answer to this request sentence is described in chapter 2.3.5

2.2.6 INTCOMP Internal compass data request

\$PRHO , xxx , R , INTCOMP*hh<CR><LF>

This sentence requests data of internal compass.

Internal compass data contains:

- Status flag (not installed, working, working uncal)
- Compass heading (without deviation and variation)
- Refresh time

The answer to this request sentence is described in chapter 2.3.6

2.2.7 DFSTD DF standard data request

\$PRHO , xxx , R , DFSTD*hh<CR><LF>

This sentence requests standard DF data.

Standard DF data contains:

- Error code
- Warning code
- Mode of operation
- RX-frequency
- Squelch threshold
- Signal level
- Relative bearing
- Absolute bearing true reference
- Absolute bearing magn reference
- Relative "live" bearing (without averaging)

The answer to this request sentence is described in chapter 2.3.7

2.2.8 IVOLT Voltage data request

\$PRHO , xxx , R , IVOLT*hh<CR><LF>

This sentence requests the voltage data's.

Voltage data contains:

- Voltages of all connected parts

The answer to this request sentence is described in chapter 2.3.8

2.2.9 AF Audio frequency data request

\$PRHO , xxx , R , AF*hh<CR><LF>

This Sentence requests the audio frequency of the signal.

AF data contains:

- Audio frequency of the received signal

The answer to this request sentence is described in chapter 2.3.9

2.2.10 STAT Statistics data request

\$PRHO , xxx , R , STAT*hh<CR><LF>

This Sentence requests the statistics data of the DF.
AF data contains:

- ON Time
- ON Counter
- Various processor reset sources

The answer to this request sentence is described in chapter 2.3.12

2.2.11 DIMC Dimming/contrast settings request

\$PRHO , xxx , R , DIMC*hh<CR><LF>

This sentence requests the dimming and contrast settings.
Dimming and contrast settings containing:

- Led circle dimming
- Legend illumination dimming
- Display backlight dimming
- Display contrast

The answer to this request sentence is described in chapter 2.3.10

2.2.12 VOL Volume settings request

\$PRHO , xxx , R , VOL*hh<CR><LF>

This sentence requests volume settings.
Volume settings containing:

- NF volume (signal volume)
- Beep volume
- Alarm volume

The answer to this request sentence is described in chapter 2.3.11

2.2.13 PHASECAL Phase calibration setting request

\$PRHO , xxx , R , PHASECAL *hh<CR><LF>

This sentence requests phase calibration settings.

Phase calibration setting contains:

- Phase calibration value

The answer to this request sentence is described in chapter 2.3.13

2.2.14 EXTIN External input Status request

\$PRHO , xxx , R , EXTIN *hh<CR><LF>

This sentence requests the status of the external input.

The answer to this request sentence is described in chapter 2.3.14

2.2.15 OFFSET Bearing offset request

\$PRHO , xxx , R , OFFSET *hh<CR><LF>

This sentence requests the bearing offset value from the setup menu.

The answer to this request sentence is described in chapter 2.3.15

2.2.16 BID Beacon-Information request

\$PRHO , xxx , R , BID *hh<CR><LF>

This sentence requests the beacon information if present.

Beacon Information contains:

- Beacon ID
- Time since last reception of BeaconID
- Debug-Values

The answer to this request sentence is described in Chapter 2.3.16

2.3 Data out sentences

Data out of the DF is handled by a proprietary NMEA 0183 sentence. For most data a set of data-out sentences were created. The data sentence body consists always of the following elements:

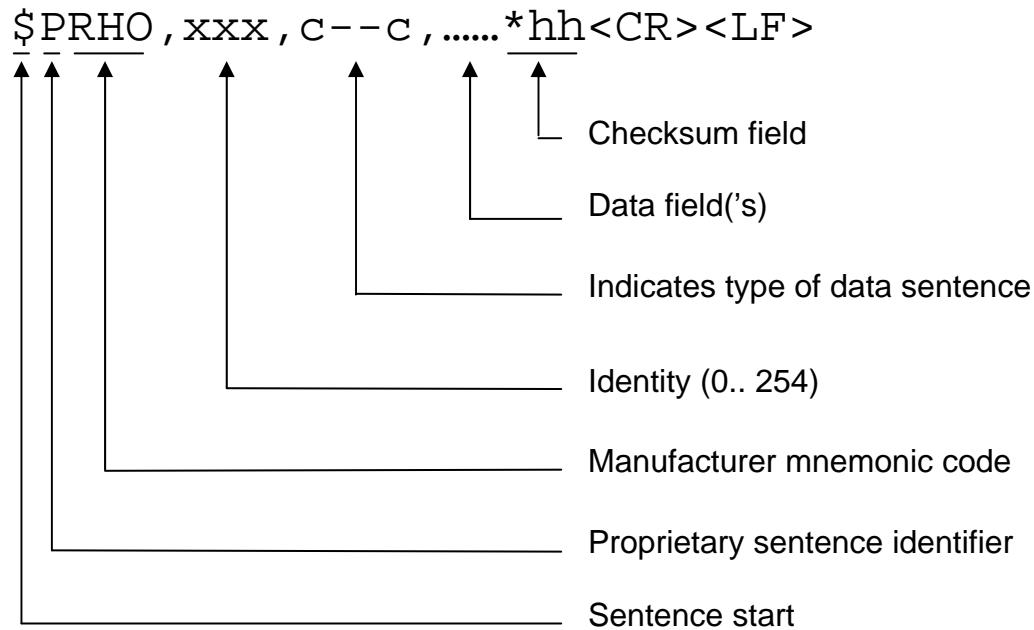

xxx is an identity field of numeric characters. The value is in the range of 0 to 254. The used format is without leading zeros. All data out from the DF is marked with the identity selected in setup. So the identity allows to separate data from different DF's connected to one RX.

c—c is a variable text field, which describes the type of data in this sentence.

2.3.1 INFGEN General info sentence

\$PRHO , xxx , INFGEN , c--c , c--c , c--c *hh<CR><LF>

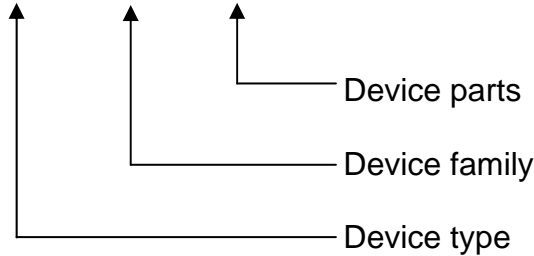

2.3.1.1 Device type:

For the RT-300 the device Type is "DF" (for direction finder)

2.3.1.2 Device family:

The device family is "RT300"

2.3.1.3 Device parts:

The different parts in the device are separated with a semicolon

For the default RT-300 the output will be "DCU;REC".

DCU = Display control unit

REC = Receiver

2.3.1.4 Example A of a DF output:

\$PRHO , xxx , INFGEN , DF , RT300 , DCU ; REC *hh<CR><LF>

It means that this device is a direction finder of the RT-300 family, which consists of a display control unit and a receiver.

2.3.2 INFPART Part info sentence

\$PRHO,xxx,INFPART,c--c,c--c,cc_,cc_,cc_*hh<CR><LF>

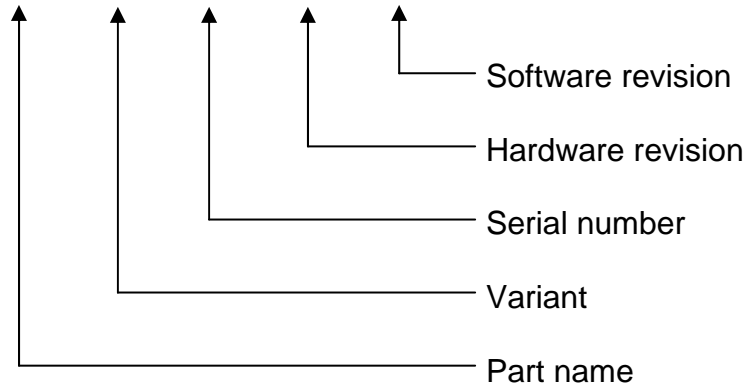

2.3.2.1 Part name:

For the standard RT-300 the part name is either "DCU or REC"

2.3.2.2 Variant:

For the DCU is up to now only the standard variant "STD" defined.

The receiver is up to now available in the following variants:

- "VS" (VHF – SHIP)
- "VU" (VHF – UHF)
- "RA" (Radio amateur)
- "FA" (Falk finder)

2.3.2.3 Serial number:

The serial number is a fixed field of 7 valid characters and looks normally "05.3234".

2.3.2.4 Hardware revision:

The hardware revision is a fixed field of 5 valid characters and looks normally "01.02".

2.3.2.5 Software revision:

The software revision is a fixed field of 5 valid characters and looks normally "01.02".

2.3.2.6 Example A of a DF output:

\$PRHO,xxx,INFPART,DCU,STD,03.2345,01.00,02.11<CR><LF>

It means the DCU part of the DF is a standard variant with serial: 03.2345, hardware revision 01.00 and software revision 02.11.

2.3.2.7 Example B of a DF output:

```
$PRHO ,xxx , INFPART , REC , VS , 01.2345 , 02.10 , 01.11 <CR><LF>
```

It means the receiver part of the DF is a VHF-SHIP variant with serial: 01.2345, hardware revision 02.10 and software revision 01.11.

2.3.3 INFREC Receiver info sentence

```
$PRHO ,xxx , INFREC , x . x , c - - c , x . x , cc ___ *hh <CR><LF>
```

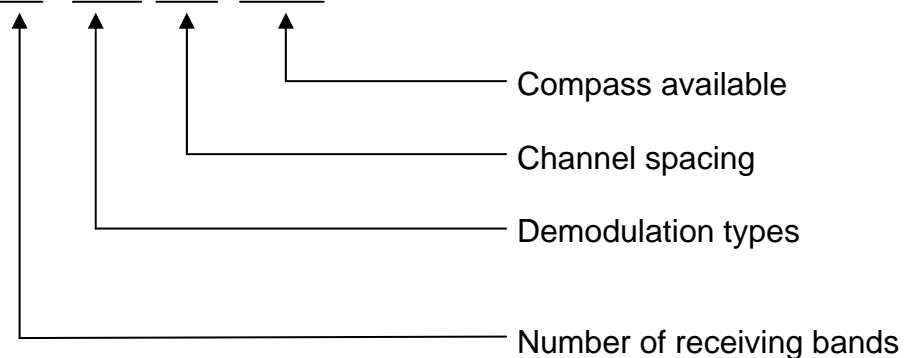

2.3.3.1 Number of receiving bands:

For the standard RT-300 the number of available receiving bands is "2".

2.3.3.2 Demodulation types:

The possible demodulation types are separated with a semicolon.

Up to now the following demodulation types are defined:

- FM
- AM
- CW
- FSK
- ASK

The typical output for a receiver variant VS is "AM;FM"

2.3.3.3 Channel Spacing:

Channel spacing will be transmitted in MHz.

The typical output for a receiver variant VS is "0.025" which means a channel spacing of 25 kHz.

2.3.3.4 Compass available:

If this field is empty, there is no compass installed.

If field contains "A" means, there is a compass installed.

2.3.3.5 Example A of a DF output:

```
$PRHO , xxx , INFREC , 2 , AM ; FM , 0 . 025 , *hh <CR> <LF>
```

It means the receiver has 2 receiving bands. AM and FM demodulation is possible. The channel spacing is 25 kHz and there is no internal compass installed.

2.3.3.6 Example B of a DF output:

```
$PRHO , xxx , INFREC , 2 , AM ; FM , 0 . 025 , A *hh <CR> <LF>
```

It means the receiver has 2 receiving bands. AM and FM demodulation is possible. The channel spacing is 25 kHz and there is a internal compass installed.

2.3.4 INFDCU DCU Info Sentence

```
$PRHO , xxx , INFDCU , c--c *hh <CR> <LF>
```

↑
Available modes (features)

2.3.4.1 Special mode types (features):

The possible mode types are separated with a semicolon.
Up to now the following mode types are defined:

- "S" Scan mode
- "E" Only ELT mode
- "D" Decoding of digital BeaconID-Data

The typical output for a standard DCU is "S;E;D"

2.3.4.2 Example A of a DF output:

```
$PRHO , xxx , INFDCU , S ; E ; D <CR> <LF>
```

It means the DCU part of the DF has scan mode, only ELT mode, and an audio frequency counter integrated. Additionally the DCU is capable of decoding digital BeaconID-Messages.

2.3.5 INFBAND Band info sentence

\$PRHO,xxx,INFREC,x.x,c--c,x.x,x.x,x.x,cc*hh<CR><LF>

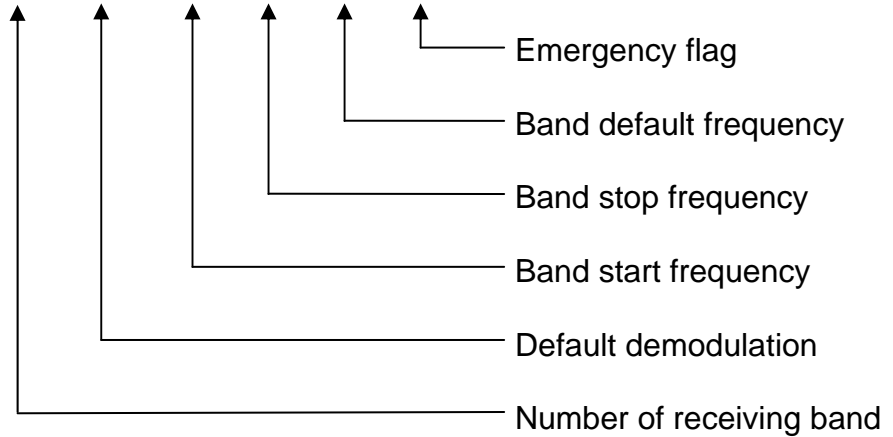

2.3.5.1 Number of receiving band:

For the standard RT-300 the possible numbers of the receiving bands are:

- "0" Band 0
- "1" Band 1

2.3.5.2 Default demodulation:

The default demodulation type in this band.

Up to now the following demodulation types are defined:

- FM
- AM
- CW
- FSK
- ASK

The typical output for a Receiver variant VS is "AM"

2.3.5.3 Band start frequency:

Start frequency of this band in MHz.

The typical output for a receiver variant VS in band 0 is "118.000" which means a start frequency of 118.000 MHz

2.3.5.4 Band stop frequency:

Stop frequency of this band in MHz.

The typical output for a receiver variant VS in band 0 is "124.000" which means a stop frequency of 124.000 MHz

2.3.5.5 Band default frequency:

Default frequency of this band in MHz. The default is either the emergency frequency or the most used frequency (e.g. 156.800 in the sea Band) The typical output for a

receiver variant VS in band 0 is "121.500" which means a default frequency of 121.000 MHz.

2.3.5.6 Emergency flag:

This field is empty, if the band contains no emergency frequency.
If the default frequency is an emergency frequency, the field contains an "T"

2.3.5.7 Example A of a DF output:

```
$PRHO,xxx,INFREC,0,AM,118.000,124.000,121.500,T*hh<CR><LF>
```

The receiver band 0 uses AM demodulation. The band range goes from 118 MHz to 124 MHz. The default frequency is 121.500 MHz and is an emergency frequency.

2.3.5.8 Example B of a DF output:

```
$PRHO,xxx,INFREC,1,FM,156.000,162.000,156.800,*hh<CR><LF>
```

The receiver 1 band uses FM demodulation. The band range goes from 156 MHz to 162 MHz. The default frequency is 156.800 MHz. There is no emergency frequency in this band.

2.3.6 INTCOMP Internal compass data sentence

```
$PRHO,xxx,INTCOMP,cc__,x.x,x.x,x.x,x.x*hh<CR><LF>
```

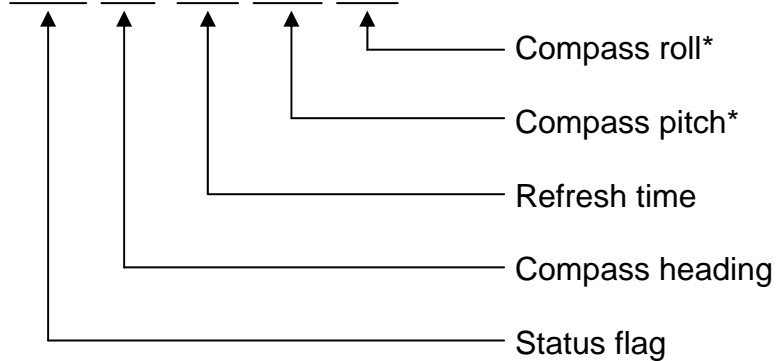

- = only available with 3 axis compass option

2.3.6.1 Status flag:

The status Flag consists of one valid character:

- "" Empty Field means no compass installed
- "A" means, 2 axis compass installed and working
- "U" means, 2 axis compass working, but uncalibrated
- "D" means, 3 axis compass installed and working
- "C" Compass currently calibrating

2.3.6.2 Compass heading:

The heading of the internal magnetic compass in degrees without deviation and variation. "120.0" means 120.0 degrees.

2.3.6.3 Refresh time:

Refresh time of the internal magnetic compass value in milliseconds. "250" means a refresh time of 250 ms.

2.3.6.4 Compass Pitch:

Pitch of the compass module. This value is only available, if the DF contains the optional 3 axis compass. Result can be negative.

"20.0" means +20.0 degrees.

"-3.4" means -3.4 degrees.

2.3.6.5 Compass Roll:

Pitch of the compass module. This value is only available, if the DF contains the optional 3 axis compass. Result can be negative.

"20.0" means +20.0 degrees.

"-3.4" means -3.4 degrees.

2.3.6.6 Example A of a DF output:

```
$PRHO ,xxx ,INTCOMP ,A ,134.5 ,250 , , *hh<CR><LF>
```

It means the internal 2 axis compass is active and calibrated. It has an actual heading of 134.5 deg and will be refreshed every 250 ms.

2.3.6.7 Example B of a DF output:

```
$PRHO ,xxx ,INTCOMP ,D ,67.3 ,250 ,3.9 , -2.1 *hh<CR><LF>
```

It means the internal 3 axis compass is active. It has an actual heading of 67.3 deg and will be refreshed every 250 ms. Pitch is 3.9 deg and Roll is -2.1 deg.

2.3.7 DFSTD Standard DF sentence

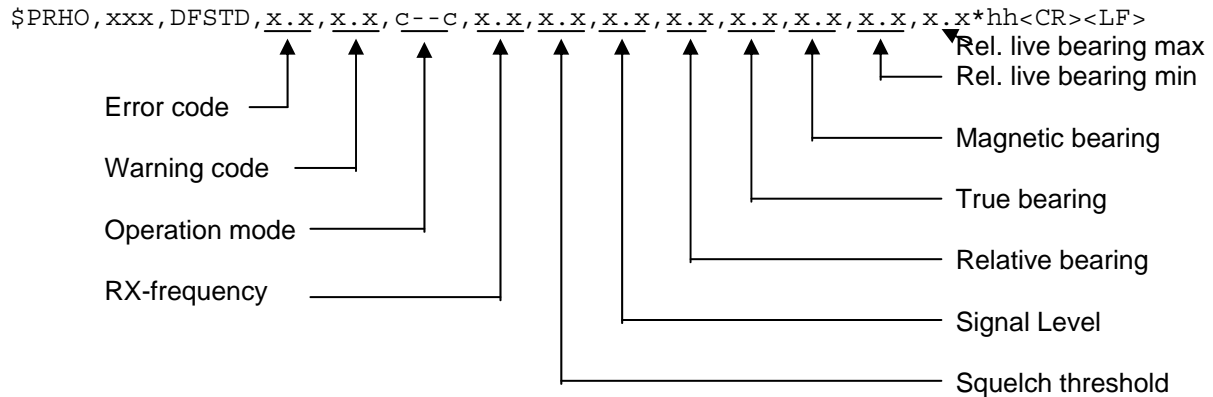

2.3.7.1 Error code:

Only the error with the highest priority (beginning at “1”) will be displayed. Up to now the following error codes are defined:

- “1” Display voltage to low
- “2” Receiver(antenna) voltage to low
- “3” No antenna connected
- “4” Bad data from antenna
- “5” Bad data from display
- “6” PLL-LOCK error
- “7” PLL-synth error
- “8” Not used up to now, but reserved
- “9” Offset + error
- “10” Offset – error

For a detailed description look into DF manual.

2.3.7.2 Warning code:

Only the warning with the highest priority (beginning at “1”) will be displayed. Up to now the following error codes are defined:

- “1” Display voltage low
- “2” Receiver(antenna) voltage low
- “3” No heading data, but absolute bearing selected
- “4” No compensation

For a detailed description look into DF manual.

2.3.7.3 Operation mode:

If no special operation mode is selected, this field will be empty.

The different operation modes are separated with a semicolon.

Up to now, the following modes are defined:

- “S” Scan Mode
- “E” ELT only Mode

- “D” Data Mode (Digital Beacon Information is available -> Beacon Information can be fetched with BID-Request; see 2.2.16)

In this field are up to 3 Modes allowed to be conform to the NMEA 82Char per sentence limit.

2.3.7.4 RX-frequency:

Current receiving frequency in MHz.

“121.500” means a current receiving frequency of 121.500 MHz

2.3.7.5 Squelch threshold:

Receiver squelch threshold in %. The range is “0.0” up to “100.0”

“36.5” means a squelch threshold of 36,5% .

2.3.7.6 Signal level:

Receiver signal Level in %. The range is “0.0” up to “100.0”

“31.5” means a signal level of 36,5%

2.3.7.7 Relative bearing:

Relative bearing field contains the bearing in degrees.

“300.5” means a relative (reference is the ship bow) bearing of 300.5 degrees.

2.3.7.8 Absolute true bearing:

True bearing field contains the bearing in degrees.

“60.5” means a absolute (reference is true north) bearing of 60.5 degrees. We don't recommend to use this field in a sea chart or similar device. Please calculate the true bearing again in the sea chart system, otherwise you could have inconsistent bearing data in case of an DF compass failure or setup mistake.

2.3.7.9 Absolute magnetic bearing:

Magnetic Bearing field contains the bearing in degrees.

“62.5” means a absolute (reference is magnetic north) bearing of 62.5 degrees. We don't recommend to use this field in a sea chart or similar device. Please calculate the true bearing again in the sea chart system from the relative bearing data, otherwise you could have inconsistent bearing data in case of an DF compass failure or setup mistake.

2.3.7.10 Relative live bearing min/max:

Relative live bearing fields contains the bearing in degrees without averaging. The relative live bearing reacts faster than the normal relative bearing, but it has not the precision of the averaged bearing. The values are the min / max Live-Value since last DFSTD sentence

“300.5” means a relative live (reference is the ship bow) bearing of 300.5 degrees.

2.3.7.11 Example A of a DF output:

```
$PRHO,xxx,DFSTD,0,0,,121.500,32.5,28.0,,,,*hh<CR><LF>
```

No error, no warning -> Device is ok
 Empty mode field -> No special mode is active
 121.500 -> receiving frequency is 121.500 MHz
 32.5 -> Squelch threshold is 32.5%
 28.0 -> Signal level is 28.0%
 Empty bearing fields -> No bearing present

This example shows a standard operation on 121.500 MHz where the signal is under the squelch threshold and therefore is no bearing present.

2.3.7.12 Example B of a DF output:

```
$PRHO,xxx,DFSTD,0,0,S;E,121.500,32.5,68.0,30.0,,,31.5,37.0*hh<CR><LF>
```

No error, No warning -> Device is ok
 S;E -> Scan mode and only ELT mode is active
 121.500 -> receiving frequency is 121.500 MHz
 32.5 -> Squelch threshold is 32.5%
 68.0 -> Signal level is 68.0%
 30.0 -> relative averaged bearing is 30.0 degrees
 empty field (true bearing) -> No reference for absolute true bearing present
 (or not selected in setup)
 empty field (magn. bearing)-> No reference for absolute magn bearing present (or
 not selected in setup)
 31.5 -> Relative live bearing min is 31.5 degrees / max is 37.0°

This example shows a standard operation on 121.500 MHz where the signal is over the squelch threshold. Because special mode “only ELT” is active and a bearing is present, the received signal has an ELT modulation. → The transmitter is an emergency locator beacon. The reason, because there is no absolute bearing present may be the missing compass reference or a setup failure.

2.3.7.13 Example C of a DF output:

```
$PRHO,xxx,DFSTD,0,0,D,243.000,25.0,95.0,30.0,60.0,63.0,31.5,37.0*hh<CR><LF>
```

No error, No warning -> Device is ok
 D -> BeaconID was received and can be fetched
 243.000 -> receiving frequency is 243.000 MHz
 25.0 -> Squelch threshold is 25.0%
 95.0 -> Signal level is 95.0% (very strong signal)
 30.0 -> Relative averaged bearing is 30.0 degrees
 60.0 -> Absolute true bearing is 60.0 degrees
 63.0 -> Absolute magnetic bearing is 63.0 degrees

31.5

-> Relative live bearing min is 31.5 degrees / max is 37.0°

This example shows a standard operation on 243.000 MHz where the signal is over the squelch threshold. A relative bearing and both absolute bearings are present. The signal level is 95% and that is close to 100%, therefore the transmitter is not far away.

2.3.8 IVOLT Internal voltages data sentence

\$PRHO , xxx , IVOLT , c--c , x . x*hh<CR><LF>

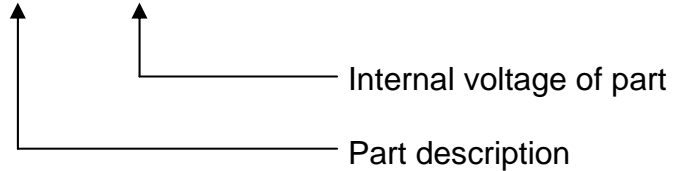

Up to 8 parts are allowed in this sentence.

2.3.8.1 Part description:

For the standard RT-300 the part name is either “DCU or REC”

2.3.8.2 Internal voltage of part :

The internal voltage of the part in volt.
“14.8” means 14.8 Volt

2.3.8.3 Example A of a DF output:

\$PRHO , xxx , IVOLT , DCU , 13 . 4 , REC , 12 . 8 *hh<CR><LF>

It means that the DCU has an input voltage of 13.4 Volt and the receiver has an input voltage of 12.8 Volt.

2.3.9 AF Audio frequency data sentence

\$PRHO , xxx , AF , x . x*hh<CR><LF>



2.3.9.1 Audio frequency:

Audio frequency of the demodulated receiver signal in Hz.
“600” means 600 Hz Audio frequency.
The range is from “0” Hz to “2550”.

2.3.9.2 Example A of a DF output:

\$PRHO , xxx , AF , 1750 *hh<CR><LF>

It means that the demodulated RF Signal has an audio frequency of 1750 Hz.

2.3.10 DIMC Dimming/contrast data sentence

\$PRHO , xxx , DIMC , x . x , x . x , x . x , x . x *hh<CR><LF>

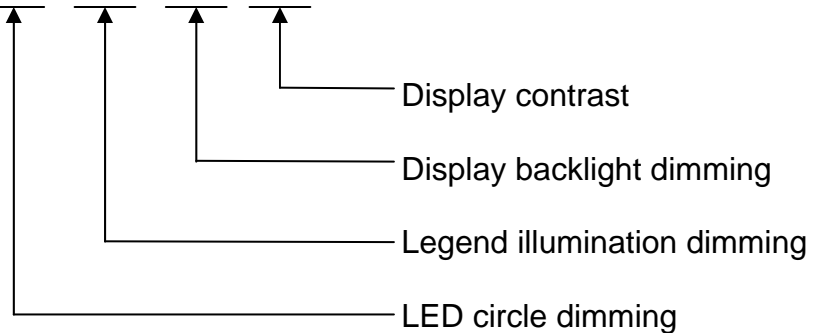

2.3.10.1 LED circle dimming:

LED circle dimming in the range from 0% to 100%.

2.3.10.2 Legend illumination dimming:

Legend illumination dimming in the range from 0% to 100%.

2.3.10.3 Display backlight dimming:

Display backlight dimming in the range from 0% to 100%.

2.3.10.4 Display contrast:

Display contrast of the LCD display in the range from 0% to 100%.

2.3.10.5 Example A of a DF output:

\$PRHO , xxx , DIMC , 100 , 22 , 70 , 45 *hh<CR><LF>

LED circle dimming	->	100%
Legend illumination dimming	->	22%
Display backlight dimming	->	70%
Display contrast	->	45%

2.3.11 VOL Volume data sentence

\$PRHO,xxx,VOL,x.x,x.x,x.x*hh<CR><LF>

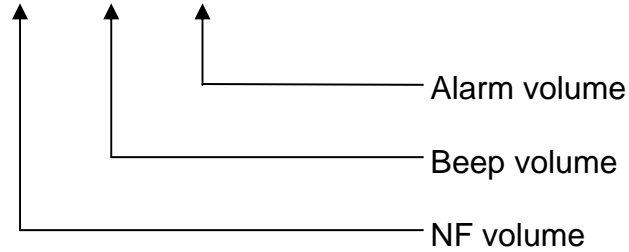

2.3.11.1 Volume:

NF volume in the range from 0% to 100%.

2.3.11.2 Beep Volume:

Beep volume in the range from 0% to 100%.

2.3.11.3 Alarm Volume:

Alarm volume in the range from 0% to 100%.

2.3.11.4 Example A of a DF output:

\$PRHO,xxx,VOL,76,20,100*hh<CR><LF>

NF volume	->	76%
Beep volume	->	20%
Alarm volume	->	100%

2.3.12 STAT **Statistic data sentence**

\$PRHO,xxx,STAT,x.x,x.x,x.x,x.x,x.x,x.x*hh<CR><LF>

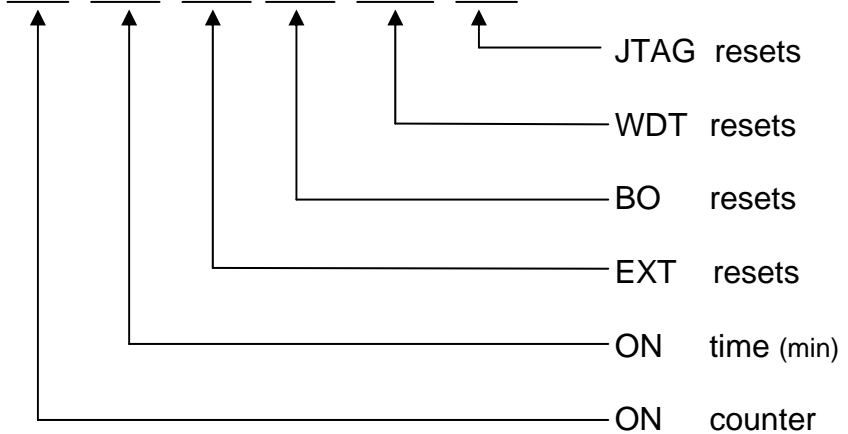

2.3.12.1 ON counter

ON counter counts the switching on procedures.
The output range is between 0 and 99999999.

2.3.12.2 ON time

ON counter counts the running time of the DF in minutes.
The output range is between 0 and 99999999.

2.3.12.3 EXT resets

External reset counter.
The output range is between 0 and 255.

2.3.12.4 BO resets

Brown out reset counter.
The output range is between 0 and 255.

2.3.12.5 WDT resets

Watchdog reset counter.
The output range is between 0 and 255.

2.3.12.6 JTAG resets

JTAG reset counter.
The output range is between 0 and 255.

2.3.12.7 Example A of a DF output:

```
$PRHO , xxx , STAT , 1376 , 2093246 , 35 , 1 , 0 , 0 *hh<CR><LF>
```

DF switched on	1376	times.
DF runs totally	2093246	minutes.
Total external resets:	35	
Total Brown out resets:	1	
Total WDT resets:	0	
Total JTAG resets:	0	

2.3.13 PHASECAL Phase calibration data Sentence

```
$PRHO , xxx , PHASECAL , x . x *hh<CR><LF>
```

↑
Phase Calibration value

2.3.13.1 Phase calibration value

Phase calibration field contains actual Phase calibration value in degrees.

2.3.13.2 Example A of a DF output:

```
$PRHO , xxx , PHASECAL , 137 *hh<CR><LF>
```

Actual Phase calibration value: 137 degrees

2.3.14 EXTIN External Input status Sentence

```
$PRHO , xxx , EXTIN , x . x *hh<CR><LF>
```

↑
External Input Status

2.3.14.1 External input status

Phase calibration field contains actual Phase calibration value in degrees.

- "0" External Input state is high
- "1" External Input State is low

2.3.14.2 Example A of a DF output:

```
$PRHO , xxx , EXTIN , 0 *hh<CR><LF>
```

Actual external input is "low"

2.3.15 OFFSET Bearing offset data Sentence

\$PRHO , xxx , OFFSET , x . x *hh<CR><LF>

↑
Bearing offset

2.3.15.1 Bearing offset

Bearing offset from the setup menu in degrees. The range is "0" up to "359"

- "31" means a bearing offset of 31 degrees

2.3.15.2 Example A of a DF output:

\$PRHO , xxx , OFFSET , 0 *hh<CR><LF>

actual bearing offset is 0 degrees

2.3.16 INFBID Beacon Information sentence

\$PRHO , x , INFBID , x , C - - C , xx . xx , xx . xx , xxx , xxx , x , xxx *hh <CR> <LF>

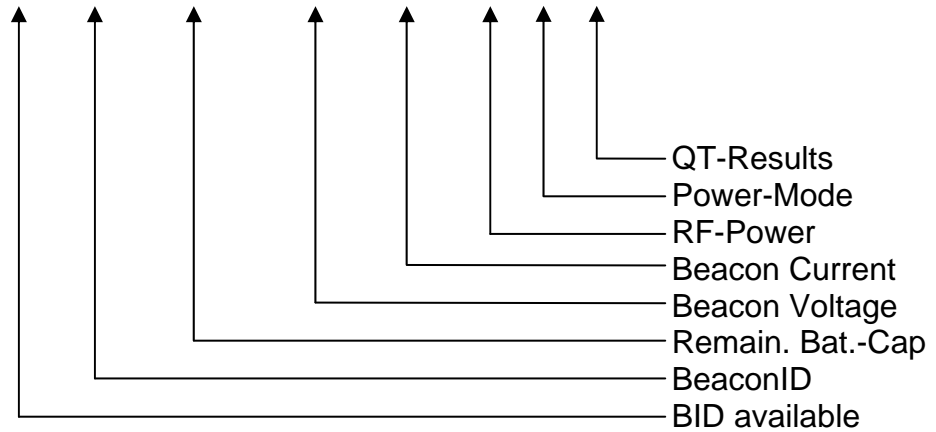

2.3.16.1 BID available

“1”: At least one digital BeaconID-Message was received.

“0”: No BeaconID-Message received yet.

2.3.16.2 BeaconID

Received BeaconID
8 Characters, if valid.

2.3.16.3 Remaining Battery-Capacity

The remaining capacity of the Beacon-Battery in [%].
The output range is 0.0% - 99.99%.

2.3.16.4 Beacon Voltage

The battery-voltage of the beacon during transmission.
The output range is between 0.0V and 10.00V.

2.3.16.5 Beacon current

The beacon-current during transmission.
The output range is between 0mA and 511mA.

2.3.16.6 RF-Power

The measured RF-Power of the beacon during transmission in [digit]
The output range is between 0 and 1023.

2.3.16.7 Powermode

The current powermode of the beacon.
“0” = High Power Mode, “1” Normal Power Mode, “2” Low Power Mode.

2.3.16.8 Results of internal Quicktest

The results of the internal quicktest.
The output range is between 0 and 255.

2.3.16.9 Example A of a DF output:

```
$PRHO,x,R,INFBID,1,BEACON05,95.23,7.99,159,248,0,1*hh  
<CR><LF>
```

BeaconID is available: Yes
BeaconID BEACON05
Remaining Battery Cap.: 95.23%
Beacon Voltage: 7.99V
Beacon Current: 159mA
Beacon RF-Power: 248 digits
Beacon Power Mode: 0 (High Power Mode)
Beacon Quicktest results: 1 (Quicktest OK)

2.3.16.10 Example B of a DF output:

```
$PRHO,x,INFBID,1,BEACON05,95.23,,,,,0,*hh<CR><LF>
```

BeaconID is available: Yes
BeaconID BEACON05
Remaining Battery Cap.: 95.23%
Beacon Voltage: not available yet
Beacon Current: not available yet
Beacon RF-Power: not available yet
Beacon Power Mode: 0 (High Power Mode)
Beacon Quicktest results: not available yet

2.3.16.11 Example C of a DF output:

```
$PRHO,x,INFBID,0,,,,,,,,,*hh<CR><LF>
```

BeaconID is available: NO
BeaconID not available
Remaining Battery Cap.: not available
Beacon Voltage: not available
Beacon Current: not available
Beacon RF-Power: not available
Beacon Power Mode: not available
Beacon Quicktest results: not available

2.3.17 CMDOK Command OK

\$PRHO , xxx , CMDOK *hh<CR><LF>

The requested operation finished successfully.

2.3.18 ERRCMD Command unknown error

\$PRHO , xxx , ERRCMD *hh<CR><LF>

This sentence is the answer to an unknown request or control sentence.

2.3.19 ERRFIELD Field unknown error

\$PRHO , xxx , ERRFIELD *hh<CR><LF>

This sentence is the answer to an unknown field descriptor in a known sentence.

2.3.20 ERRRANGE Field value out of range error

\$PRHO , xxx , ERRRANGE *hh<CR><LF>

This sentence is the answer to a value field, which is out of range or not in the right spacing.

2.4 Remote control sentences

Remote control of the DF is handled by a set of proprietary NMEA 0183 sentences. The control sentence body consists always of the following elements:

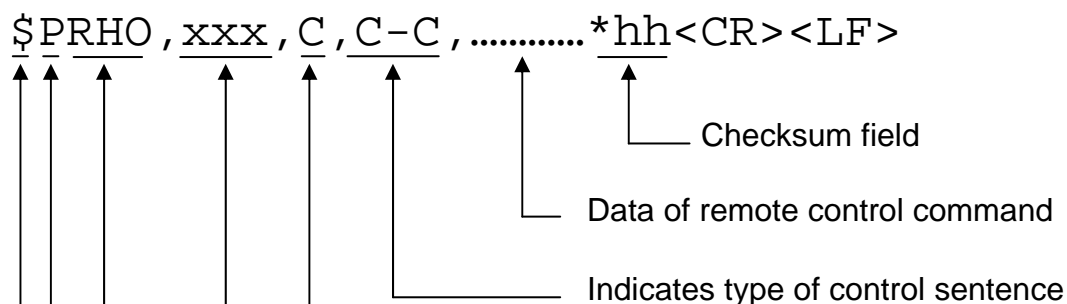

_____	Indicates a control sentence
_____	Identity (0 ... 255)
_____	Manufacturer mnemonic code
_____	Proprietary sentence identifier
_____	Sentence start

xxx is an identity field of numeric characters. The value must be in the range of 0 to 255. The usable format is equal to NMEA0183 (004=04=4). The DF only reacts to the control sentences if the identity is 255 or it's equal to the one selected in setup. So the identity allows to access different DF's connected to one TX.

c—c is a variable text field, which describes the type of data in this sentence.

2.4.1 EEOP Load/Save values from/to eeprom

On every start-up the DF loads the settings from eeprom into ram. If settings are changed via the setup menu, the new values are automatically stored in the eeprom too. But if settings changed via a serial command, the values are not stored in the eeprom. Therefore the changed settings are not available after the next power-up. For storing the current settings in the eeprom and for loading the old settings from eeprom was this operation defined.

\$PRHO , xxx , C , EEOP , cc__*hh<CR><LF>

↑
Type of eeprom operation

The answer to a successful eeprom operation will be the CMDOK sentence, which is described in chapter 2.3.17 .

2.4.1.1 Type of eeprom operation:

- "L" loads settings from eeprom into the ram
- "S" save current settings from ram to the eeprom

2.4.1.2 Example A of a typical control sentence:

\$PRHO , xxx , C , EEOP , L*hh<CR><LF>

This sentence loads settings stored in eeprom into the ram.

2.4.1.3 Example B of a typical control sentence:

\$PRHO , xxx , C , EEOP , S*hh<CR><LF>

This sentence save's the current settings from ram to eeprom.

2.4.2 FREQU Set receiving frequency & band

This sentence set the current receiving frequency. If the frequency is not included in the current receiving band, the DF will choose the correct band automatically.

```
$PRHO , xxx , C , FREQU , x . x * hh <CR> <LF>
```

↑
Receiving frequency

The answer to a successful FREQU command will be the DFSTD sentence, which is described in chapter 2.3.7.

If the operation was not successful, the answer is one of the three error sentences ERRCMD(2.3.18), ERRFIELD(2.3.19) or ERRRANGE (2.3.20) .

2.4.2.1 Receiving frequency:

This field contains the receiving frequency in MHz. "121.500" means a frequency of 121.500 MHz. If the frequency is not a multiple of the receiver channel spacing, the nearest receiving frequency will be set as new receiving frequency. If the receiver is not able to receive at the frequency of the field, the ERRRANGE (Chapter: 2.3.20) sentence will be the answer instead of the DFSTD sentence. Therefore we recommend to make a "Band Info request" (Chapter: 2.3.5) for all receiving bands to receive the band start and stop frequency.

2.4.2.2 Example A of a typical control sentence:

```
$PRHO , xxx , C , FREQU , 121 . 650 * hh <CR> <LF>
```

The new receiving frequency will be 121.650 MHz

2.4.2.3 Example B of a typical control sentence:

```
$PRHO , xxx , C , FREQU , 121 . 510 * hh <CR> <LF>
```

The new frequency is not available, because the receiver channel spacing is 25 kHz.

Therefore the new receiving frequency is 121.500 MHz.

2.4.3 SQU Set squelch threshold

This sentence set the squelch threshold in the current receiving band.

```
$PRHO , xxx , C , SQU , x . x *hh<CR><LF>
```

↑
_____ squelch threshold

The answer to a successful SQU command will be the DFSTD sentence, which is described in chapter 2.3.7.

If the operation was not successful, the answer is one of the three error sentences ERRCMD(2.3.18), ERRFIELD(2.3.19) or ERRRANGE (2.3.20) .

2.4.3.1 Squelch threshold:

This field contains the squelch threshold in %. "32.5" means a squelch threshold of 32.5%. If the threshold is not in the right spacing, the nearest possible value will be set as new squelch threshold. If the field value is not in the range from 0 to 90%, the ERRRANGE (Chapter: 2.3.20) sentence will be the answer instead of the DFSTD sentence.

2.4.3.2 Example A of a typical control sentence:

```
$PRHO , xxx , C , SQU , 35 *hh<CR><LF>
```

The new squelch threshold will be 35.0 %

2.4.3.3 Example B of a typical control sentence:

```
$PRHO , xxx , C , SQU , 35 . 435 *hh<CR><LF>
```

The new squelch threshold will be 35.5 % because the internal threshold resolution is 0.5%.

2.4.4 MODE Set special operating modes

This sentence set the special operating modes.

\$PRHO , xxx , C , MODE , c-c , cc__ *hh<CR><LF>

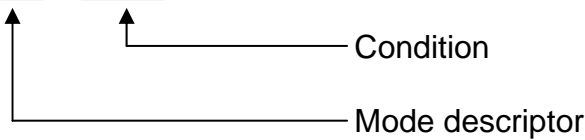

Up to 2 modes are allowed in this sentence.

The answer to a successful MODE command will be the DFSTD sentence, which is described in chapter 2.3.7.

If the operation was not successful, the answer is one of the three error sentences ERRCMD(2.3.18), ERRFIELD(2.3.19) or ERRRANGE (2.3.20) .

2.4.4.1 Mode descriptor:

Up to now, the following modes are defined:

- "S" Scan mode
- "E" ELT only mode

If the DF doesn't support the required special mode, the answer will be the ERRFIELD sentence (Chapter: 2.3.19)

Up to 3 different mode changes are allowed in one sentence.

2.4.4.2 Condition:

- "A" Activation
- "C" Deactivation (cancelling)
- empty field no condition change

For activation of a special mode, this field must contain an "A", and for deactivation a "C". If this field remains empty, the condition won't be changed.

2.4.4.3 Example A of a typical control sentence:

\$PRHO , xxx , C , MODE , E , A , S , A *hh<CR><LF>

This sentence will activate the "ELT only Mode" and the "SCAN" mode.

2.4.4.4 Example B of a typical control sentence:

\$PRHO , xxx , C , MODE , S , C *hh<CR><LF>

This sentence will deactivate the "SCAN" mode.

2.4.5 DIMC Set dimming/contrast

\$PRHO , xxx , C , DIMC , x . x , x . x , x . x , x . x *hh<CR><LF>

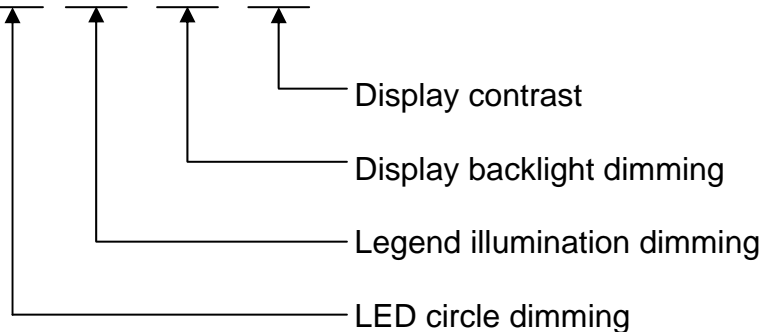

The answer to a successful DIMC command will be the DIMC sentence, which is described in chapter 2.3.10.

If the operation was not successful, the answer is one of the three error sentences ERRCMD(2.3.18), ERRFIELD(2.3.19) or ERRRANGE (2.3.20) .

2.4.5.1 LED circle dimming:

LED circle dimming in the range from 0% to 100%. If the value is not in the right spacing, the nearest possible value will be set as new value. If the field value is not in the range from 0 to 100%, the ERRRANGE (chapter: 2.3.20) sentence will be the answer instead of the DIMC sentence.

2.4.5.2 Legend illumination dimming:

Legend illumination dimming in the range from 0% to 100%. If the value is not in the right spacing, the nearest possible value will be set as new value. If the field value is not in the range from 0 to 100%, the ERRRANGE (chapter: 2.3.20) sentence will be the answer instead of the DIMC sentence.

2.4.5.3 Display backlight dimming:

Display backlight dimming in the range from 0% to 100%. If the value is not in the right spacing, the nearest possible value will be set as new value. If the field value is not in the range from 0 to 100%, the ERRRANGE (chapter: 2.3.20) sentence will be the answer instead of the DIMC sentence.

2.4.5.4 Display contrast:

Display contrast in the range from 0% to 100%. If the value is not in the right spacing, the nearest possible value will be set as new value. If the field value is not in the Range from 0 to 100%, the ERRRANGE (chapter: 2.3.20) sentence will be the answer instead of the DIMC sentence.

2.4.5.5 Example A of a typical control sentence:

\$PRHO , xxx , C , DIMC , 100 , 22 , 70 , 45 *hh<CR><LF>

LED circle dimming	->	100%
Legend illumination dimming	->	22%
Display backlight dimming	->	70%
Display contrast	->	45%

2.4.6 VOL Set volumes

\$PRHO , xxx , C , VOL , x . x , x . x , x . x *hh<CR><LF>

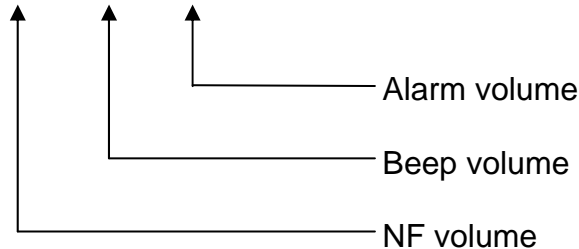

The answer to a successful VOL command will be the VOL sentence, which is described in chapter 2.3.11.

If the operation was not successful, the answer is one of the three error sentences ERRCMD(2.3.18), ERRFIELD(2.3.19) or ERRRANGE (2.3.20) .

2.4.6.1 NF volume:

NF volume in the range from 0% to 100%. If the value is not in the right spacing, the nearest possible value will be set as new value. If the field value is not in the range from 0 to 100%, the ERRRANGE (chapter: 2.3.20) sentence will be the answer instead of the VOL sentence.

2.4.6.2 Beep volume:

Beep volume in the range from 0% to 100%. If the value is not in the right spacing, the nearest possible value will be set as new value. If the field value is not in the range from 0 to 100%, the ERRRANGE (chapter: 2.3.20) sentence will be the answer instead of the VOL sentence.

2.4.6.3 Alarm volume:

Alarm volume in the range from 0% to 100%. If the value is not in the right spacing, the nearest possible value will be set as new value. If the field value is not in the range from 0 to 100%, the ERRRANGE (chapter: 2.3.20) sentence will be the answer instead of the VOL sentence.

2.4.6.4 Example A of a typical control sentence:

\$PRHO , xxx , C , VOL , 80 , 40 , 34 *hh<CR><LF>

NF volume	->	80%
Beep volume	->	40%
Alarm volume	->	34%

2.4.7 BAUD Set serial baud rate

For the DF a baud rate change via a serial command is possible. Pay attention, because the baud rate of the communication partner has to be changed too!

```
$PRHO , xxx , C , BAUD , x . x * hh <CR> <LF>
```

↑
Baud rate number

The answer to a successful baud rate setting will be the CMDOK sentence at the new baud rate, which is described in chapter 2.3.17 .

2.4.7.1 Baud rate number:

The following baud rate numbers are defined:

- "1" 1200Baud
- "2" 2400Baud
- "3" 4800Baud
- "4" 9600Baud
- "5" 14.4kBaud
- "6" 19.2kBaud
- "7" 28.8kBaud
- "8" 38.4kBaud
- "9" 57.6kBaud
- "10" 76.8kBaud
- "11" 115.2kBaud

If this field contains a non-recognised character or number, the ERRFIELD(2.3.19) or ERRRANGE (2.3.20) sentence will be the answer instead of the CMDOK sentence (chapter: 2.3.17).

2.4.7.2 Example A of a typical control sentence:

```
$PRHO , xxx , C , BAUD , 4 * hh <CR> <LF>
```

9600Baud will be the new serial communication speed.

2.4.8 RXTYPE Set serial RX Type

This sentence set the special operating modes.

```
$PRHO , xxx , C , RXTYPE , c-c*hh<CR><LF>
```

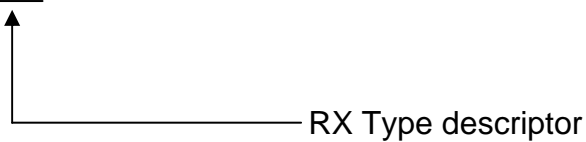

3 different receiving modes are available in this unit.

The answer to a successful MODE command will be the CMDOK sentence, which is described in chapter: 2.3.17.

If the operation was not successful, the answer is one of the two error sentences ERRCMD(2.3.18), ERRFIELD(2.3.19) .

2.4.8.1 RX Type descriptor:

Up to now, the following types are defined:

- "RS232" Standard RS232 Mode
- "NMEA" RS422 Mode with optical isolation (NMEA standard)
- "RS485" RS485 Mode

If the DF doesn't support the required RX type, the answer will be the ERRFIELD sentence (Chapter: 2.3.19)

2.4.8.2 Example A of a typical control sentence:

```
$PRHO , xxx , C , RXTYPE , RS232*hh<CR><LF>
```

The device will now listening on the RS232 Interface.

2.4.8.3 Example B of a typical control sentence:

```
$PRHO , xxx , C , RXTYPE , NMEA*hh<CR><LF>
```

The device will now listening on the NMEA (RS422) Interface.

2.4.9 TALKMODE Set serial talking mode

This sentence set the special operating modes.

```
$PRHO , xxx , C , TALKMODE , c-c *hh<CR><LF>
```

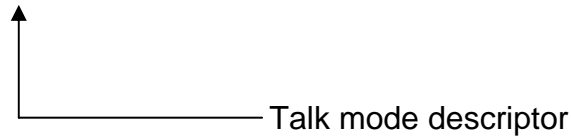

The answer to a successful TALKMODE command will be the CMDOK sentence, which is described in chapter: 2.3.17.

If the operation was not successful, the answer is one of the two error sentences ERRCMD(2.3.18), ERRFIELD(2.3.19) .

2.4.9.1 Talk mode descriptor:

Up to now, the following types are defined:

- "AUTO" Periodically transmitting the DFSTD sentence.
- "REQU" Transmit sentences only at request.

If the DF doesn't support the required talkmode, the answer will be the ERRFIELD sentence (Chapter: 2.3.19)

2.4.9.2 Example A of a typical control sentence:

```
$PRHO , xxx , C , TALKMODE , AUTO *hh<CR><LF>
```

The device will now auto talk.

2.4.9.3 Example B of a typical control sentence:

```
$PRHO , xxx , C , TALKMODE , REQU *hh<CR><LF>
```

The device will now talk only at a request.

2.4.10 ICOMPCAL Internal compass calibration

It is possible to start/stop the internal compass calibration via serial command

```
$PRHO , xxx , C , ICOMPCAL , cc__ *hh<CR><LF>
```

↑
Command flag

The answer to a successful ICOMPCAL sentence will be the INTCOMP sentence, which is described in chapter 2.3.6.

Take care if you calibrating a 2 axis or a 3 axis compass, cause for a 2 axis compass you have to drive two 360 deg turns and for the 3 axis compass you only have to drive one 360 deg turn.

If there is no internal compass in the DF installed, the answer to this command will be the ERRCMD (chapter: 2.3.18) sentence.

2.4.10.1 Command flag:

- "A" starts a internal compass calibration
- "C" stops a internal compass calibration

If this field contains a non-recognised character or number, the ERRFIELD (chapter: 2.3.19) sentence will be the answer.

2.4.10.2 Example A of a typical control sentence:

```
$PRHO , xxx , C , ICOMPCAL , A *hh<CR><LF>
```

Start an internal compass calibration.

2.4.10.3 Example B of a typical control sentence:

```
$PRHO , xxx , C , ICOMPCAL , C *hh<CR><LF>
```

Stop an internal compass calibration.

2.4.11 SETSERIAL Set serial number

\$PRHO , xxx , C , SETSERIAL , c--c , cc__ , c--c*hh<CR><LF>

Serial number
Target part name
Security string

The answer to a successful SETSERIAL command will be the INFPART sentence, which is described in chapter 2.3.2.

If the operation was not successful, the answer is the ERRCMD(2.3.18) or ERRFIELD(2.3.19) sentence.

2.4.11.1 Security string:

The security string consists of 4 valid characters and depends from device and old serial number. The security string calculation software won't be available to customers.

2.4.11.2 Part name:

For the standard RT300 the part name is either "DCU or REC"

2.4.11.3 Serial number:

The Serial number is a fixed field of 7 valid characters and looks normally "05.3234".

2.4.11.4 Example A of a typical control sentence:

\$PRHO , xxx , C , SETSERIAL , ???? , DCU , 04-1653<CR><LF>

The display control unit will get the new serial number "04-1653".
???? is the individual security string.

2.4.11.5 Example B of a typical control sentence:

\$PRHO , xxx , C , SETSERIAL , ???? , REC , 09-0815<CR><LF>

The receiver will get the new serial number "09-0815".
???? is the individual security string.

2.4.12 SETHWREV Set hardware revision

```
$PRHO , xxx , C , SETHWREV , c--c , c__c , xx.xx*hh<CR><LF>
```

Hardware revision
Target part name
Security string

The answer to a successful SETHWREV command will be the INFPART sentence, which is described in chapter 2.3.2.

If the operation was not successful, the answer is the ERRCMD(2.3.18) or ERRFIELD(2.3.19) sentence.

2.4.12.1 Security string:

The security string consists of 4 valid characters and depends from device and old serial number. The security string calculation software won't be available to customers.

2.4.12.2 Part name:

For the standard RT300 the part name is either "DCU or REC"

2.4.12.3 Hardware revision:

The hardware revision is a fixed field of 5 characters, two for the major revision followed by a dot and then two for the minor revision, e.g. "04.01".

2.4.12.4 Example A of a typical control sentence:

```
$PRHO , xxx , C , SETHWREV , ???? , DCU , 04 . 01 *xx<CR><LF>
```

The display control unit will get the new hardware revision "04.01".
???? is the individual security string.

2.4.12.5 Example B of a typical control sentence:

```
$PRHO , xxx , C , SETHWREV , ???? , REC , 03 . 20 *xx<CR><LF>
```

The receiver will get the new hardware revision "03.20".
???? is the individual security string.

2.4.13 SETDEVID Set device ident

```
$PRHO , xxx , C , SETDEVID , c--c , c__c , cccccccc*hh<CR><LF>
```

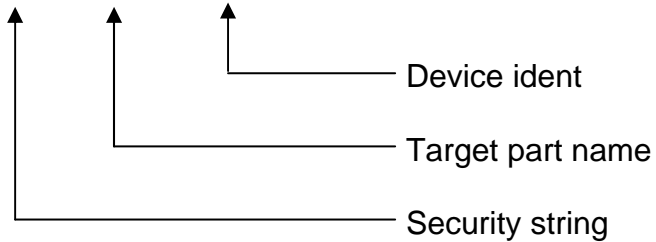

The answer to a successful SETDEVID command will be the INFPART sentence, which is described in chapter 2.3.2.

If the operation was not successful, the answer is the ERRCMD(2.3.18) or ERRFIELD(2.3.19) sentence.

2.4.13.1 Security string:

The security string consists of 4 valid characters and depends from device and old serial number. The security string calculation software won't be available to customers.

2.4.13.2 Part name:

For the standard RT300 the part name is either "DCU or REC"

2.4.13.3 Device ident:

The device ident is a fixed field of 8 characters, e.g. "RT300VU".

2.4.13.4 Example A of a typical control sentence:

```
$PRHO , xxx , C , SETDEVID , ???? , DCU , RT300DCU*xx<CR><LF>
```

The display control unit will get the new device ident "RT300DCU".

???? is the individual security string.

2.4.13.5 Example B of a typical control sentence:

```
$PRHO , xxx , C , SETDEVID , ???? , REC , RT300VU *xx<CR><LF>
```

The receiver will get the new device ident "RT300VU".

???? is the individual security string.

2.4.14 ALARM Send acoustic alarm

```
$PRHO , xxx , C , ALARM*hh<CR><LF>
```

This sentence initiates an acoustic alarm of the display control unit.
The answer to a successful execution will be the CMDOK sentence, which is described in chapter 2.3.17 and an acoustic alarm cycle afterwards.

2.4.15 REBOOT Reboot system

```
$PRHO , xxx , C , REBOOT*hh<CR><LF>
```

This sentence initiates a reboot of the complete DF.
The answer to a successful execution will be the CMDOK sentence, which is described in chapter 2.3.17 and a reboot afterwards.

2.4.16 FACTRESET Restore all factory (default) settings

```
$PRHO , xxx , C , FACTRESET*hh<CR><LF>
```

This sentence initiates a factory reset of all internal settings. Pay attention, because the serial communication baud rate might be changed. The answer to a successful execution will be the CMDOK sentence, which is described in chapter 2.3.17 and a reboot of the complete DF afterwards.

2.4.17 SWOFF Switch off system

```
$PRHO , xxx , C , SWOFF*hh<CR><LF>
```

This sentence initiates a “switch off” of the complete DF. The answer to a successful execution will be the CMDOK sentence, which is described in chapter 2.3.17 and a shutdown of the complete DF afterwards.

2.4.18 PHASECAL Phase calibration

It is possible to execute a phase calibration via serial command

```
$PRHO , xxx , C , PHASECAL , cc__*hh<CR><LF>
```

↑
Command flag

The answer to a successful PHASECAL sentence will be the CMDOK sentence, which is described in chapter 2.3.17.

If the command is not executed, the ERRCMD (chapter: 2.3.18) sentence will be the answer.

2.4.18.1 Command flag:

- “N” starts a normal phase calibration and executes afterwards a save of the new phasecal value from RAM to EEPROM.
- “I” starts an inverted phase calibration and executes afterwards a save of the new phasecal value from RAM to EEPROM.
- “O” starts a normal phase calibration. New phasecal value is only in RAM!
- “J” starts a inverted phase calibration. New phasecal value is only in RAM!

If this field contains a non-recognised character or number, the ERRFIELD(chapter: 2.3.19) sentence will be the answer.

2.4.18.2 Example A of a typical control sentence:

```
$PRHO , xxx , C , PHASECAL , N*hh<CR><LF>
```

Start a normal phase calibration.

2.4.18.3 Example B of a typical control sentence:

```
$PRHO , xxx , C , PHASECAL , I*hh<CR><LF>
```

Start an inverted phase calibration.

2.4.19 SETSTAT Set statistic values

Write values to the statistics counter

```
$PRHO,xxx,C,SETSTAT,c--c,x.x,x.x,x.x,x.x,x.x,x.x*hh<CR><LF>
```

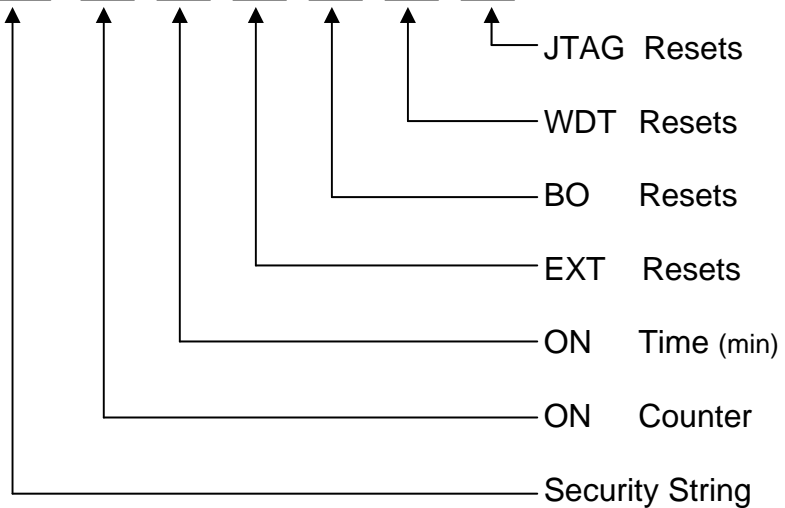

The answer to a successful SETSTAT command will be the STAT sentence, which is described in chapter 2.2.10.

If the operation was not successful, the answer is the ERRCMD(2.3.18) or ERRFIELD(2.3.19) sentence.

2.4.19.1 ON counter

ON counter counts the switching on procedures.
The allowed range is between 0 and 99999999.

2.4.19.2 ON time

ON counter counts the running time of the DF in minutes.
The allowed range is between 0 and 99999999.

2.4.19.3 EXT resets

External reset counter.
The allowed range is between 0 and 255.

2.4.19.4 BO resets

Brown out reset counter.
The allowed range is between 0 and 255.

2.4.19.5 WDT resets

Watchdog reset counter.
The allowed range is between 0 and 255.

2.4.19.6 JTAG resets

JTAG reset counter.

The allowed range is between 0 and 255.

2.4.19.7 Security string:

The security string consists of 4 valid characters and depends from device and serial number. The security string calculation software won't be available to customers.

If one ore more fields contain a non recognised character or number, the ERRFIELD(chapter: 2.3.19) sentence will be the answer.

2.4.19.8 Example of a typical control sentence:

```
$PRHO , xxx , C , SETSTAT , ???? , 0 , 0 , 0 , 0 , 0 *hh<CR><LF>
```

Reset all statistic counters to zero.

2.4.20 OFFSET Set bearing offset value

This sentence set the bearing offset value.

```
$PRHO , xxx , C , OFFSET , x . x *hh<CR><LF>
```

↑
bearing offset

The answer to a successful SQU command will be the OFFSET sentence, which is described in chapter 2.3.15.

If the operation was not successful, the answer is one of the three error sentences ERRCMD(2.3.18), ERRFIELD(2.3.19) or ERRRANGE (2.3.20) .

2.4.20.1 Bearing offset:

This field contains the bearing offset in degrees. "32" means a bearing offset of 32 degrees. If the field value is not in the range from 0 to 359, the ERRRANGE (Chapter: 2.3.20) sentence will be the answer instead of the CMDOK sentence.

2.4.20.2 Example A of a typical control sentence:

```
$PRHO , xxx , C , OFFSET , 0 *hh<CR><LF>
```

The new bearing offset will be 0 degrees.

2.4.21 BEEP Beep generation

This sentence is supposed only for testing and manufacturing. It generates a Beep with variable parameters.

```
$PRHO , xxx , C , BEEP , x . x , x . x *hh<CR><LF>
```

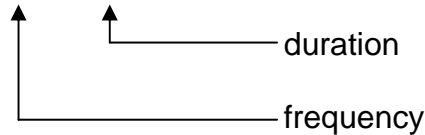

The answer to a successful BEEP command will be the CMDOK sentence, which is described in chapter 2.3.17

If the operation was not successful, the answer is one of the three error sentences ERRCMD(2.3.18), ERRFIELD(2.3.19) or ERRRANGE (2.3.20) .

2.4.21.1 Duration:

This field contains the beep duration in msec. "500" means a beep duration of 500 ms. If the field value is not in the range from 10 to 2500, the ERRRANGE (Chapter: 2.3.20) sentence will be the answer instead of the CMDOK sentence.

2.4.21.2 Frequency:

This field contains the beep frequency in Hz. "500" means a beep frequency of 800 Hz. If the field value is not in the range from 120 to 2500, the ERRRANGE (Chapter: 2.3.20) sentence will be the answer instead of the CMDOK sentence.

2.4.22 LEDON All LED's on command

This sentence is supposed only for testing and manufacturing. It switches on all LED's of the RT-300 for 4 Seconds.

```
$PRHO , xxx , C , LEDON*hh<CR><LF>
```

The answer to a successful LEDON command will be the CMDOK sentence, which is described in chapter 2.3.17

If the operation was not successful, the answer is one of the three error sentences ERRCMD(2.3.18), ERRFIELD(2.3.19) or ERRRANGE (2.3.20) .

2.4.23 LCDON All LCD digits black

This sentence is supposed only for testing and manufacturing. It switches on all digits of the RT-300 LCD display for 4 Seconds.

```
$PRHO , xxx , C , LCDON*hh<CR><LF>
```

The answer to a successful LCDON command will be the CMDOK sentence, which is described in chapter 2.3.17

If the operation was not successful, the answer is one of the three error sentences ERRCMD(2.3.18), ERRFIELD(2.3.19) or ERRRANGE (2.3.20) .

2.4.24 TESTPORT Route signal to output of testport

This sentence is supposed only for testing and manufacturing. It routes a specific internal test signal to the testport.

```
$PRHO , xxx , C , TESTPORT , x . x*hh<CR><LF>
```

↑
_____ signal

The answer to a successful TESTPORT command will be the CMDOK sentence, which is described in chapter 2.3.17

If the operation was not successful, the answer is one of the three error sentences ERRCMD(2.3.18), ERRFIELD(2.3.19) or ERRRANGE (2.3.20) .

2.4.24.1 Signal:

- "0" GND
- "1" PHI-FILT
- "2" REC-PHI
- "3" REC-NF
- "4" GND
- "5" PHASE-FILT
- "6" PHASE-LP
- "7" PHASE-IN

This field contains the signal. If the field value is not in the range from 0 to 7, the ERRRANGE (Chapter: 2.3.20) sentence will be the answer instead of the CMDOK sentence.

2.4.25 RELAY Pull the internal relay

This sentence is supposed only for testing and manufacturing. It pulls on the internal relay for a specific time

```
$PRHO , xxx , C , RELAY , x . x*hh<CR><LF>
```

↑
duration

The answer to a successful RELAY command will be the CMDOK sentence, which is described in chapter 2.3.17

If the operation was not successful, the answer is one of the three error sentences ERRCMD(2.3.18), ERRFIELD(2.3.19) or ERRRANGE (2.3.20) .

2.4.25.1 Duration:

This field contains the relay pulled duration in msec. "500" means a beep duration of 500 ms. If the field value is not in the range from 10 to 2500, the ERRRANGE (Chapter: 2.3.20) sentence will be the answer instead of the CMDOK sentence.

2.4.26 EXECBUTTON Execute button test page

This sentence is supposed only for testing and manufacturing. It calls the internal button test page.

```
$PRHO , xxx , C , EXECBUTTON*hh<CR><LF>
```

The answer to a successful EXECBUTTON command will be the CMDOK sentence, which is described in chapter 2.3.17. If the Test Page finished successfully, the RT-300 will send a INFDCU sentence, which is described in chapter 2.3.4.

If the operation was not successful, the answer is one of the three error sentences ERRCMD(2.3.18), ERRFIELD(2.3.19) or ERRRANGE (2.3.20) .

2.4.27 DEMO Control demo mode

This sentence is supposed only for testing and manufacturing. It changes the state of demo mode.

```
$PRHO , xxx , C , DEMO , x . x*hh<CR><LF>
```

↑
Mode

The answer to a successful DEMO command will be the CMDOK sentence, which is described in chapter 2.3.17

If the operation was not successful, the answer is one of the three error sentences ERRCMD(2.3.18), ERRFIELD(2.3.19) or ERRRANGE (2.3.20).

2.4.27.1 MODE:

- "1" Enable the DCU DEMO mode
- "0" Disable the DCU DEMO mode

If the field value is not 0 or 1, the ERRRANGE (Chapter: 2.3.20) sentence will be the answer instead of the CMDOK sentence.

2.4.28 AVERAGING Set averaging level

This sentence is supposed only for testing and manufacturing. It changes the state of demo mode.

```
$PRHO , xxx , C , AVERAGING , x . x*hh<CR><LF>
```

↑
Level

The answer to a successful AVERAGING command will be the CMDOK sentence, which is described in chapter 2.3.17

If the operation was not successful, the answer is one of the three error sentences ERRCMD(2.3.18), ERRFIELD(2.3.19) or ERRRANGE (2.3.20).

2.4.28.1 Level:

This field contains the internal averaging level. "5" means an averaging level of 5. If the field value is not in the range from 1 to 9, the ERRRANGE (Chapter: 2.3.20) sentence will be the answer instead of the CMDOK sentence.